

INSTRUCTION MANUAL
FOR
BESTOP STRAPPING TOOL

Model : M P L III



KohanKogyo
KOHAN KOGYO CO., LTD.



Rev.4.J

— CONTENTS —

1. Safety Instructions	-----
1-1. General precautions	
1-2. Application	
1-3. Work wear	
1-4. Protective equipment	
1-5. Precautions	
1-6. Inspection and repair	
1-7. Disposal of the tool	
1-8. Inspection before work	
2. Specifications	-----
3. Standard seal	-----
4. Pneumatic Information	-----
4-1. Air source	
4-2. Used air component	
4-3. Precautions for piping	
5. Operating Instructions and Adjustments	-----
5-1. Exterior	
5-2. Operating method	
6. Exploded-view Drawing & Bill of Materials	-----
6-1. Exploded-view Drawing : General View	
6-2. Bill of Materials : General View	
6-3. Exploded-view Drawing : Sealer	
6-4. Bill of Materials : Sealer	
6-5. Exploded-view Drawing : Tightener	
6-6. Bill of Materials : Tightener	
7. Troubleshooting	-----
8. Pneumatic circuit	-----

Safety instructions

- Before starting operation, maintenance or inspection of this device, carefully read this instruction manual.
- Contents shown in this instruction manual are described to assist safe operation and prevent danger and the damage to you and other people beforehand.
- For individual operation, observe the contents of this instruction manual. Although this device is designed and manufactured in consideration of safety, failure to follow this precaution may cause serious personal accidents such as the death or serious injuries.
- Before starting individual operation, understand the knowledge of the equipment, safety information, and all contents of this instruction manual.
- In this instruction manual, the ranks of the safety precautions have been divided with “Danger” , ”Warning” , ”Caution” ,and “Notes”.

 【 DANGER】	Indicates a hazardous situation which, if not avoided, will result in death or serious bodily injury.
 【 WARNING】	Indicates a hazardous or potentially dangerous situation which, if not avoided, could result in death or serious bodily injury.
 【 CAUTION】	Indicates a hazardous or potentially dangerous situation which, if not avoided, could result in minor or moderate bodily injury or property damage.
【※ Notes】	Indicates that mishandling may cause an operational mistake.

Even if the matter described to “Caution”, there is the possibility to relate to an important result according to the situation. Observe all safety precautions because the important contents have been described.

1. Safety Instructions

1-1. General precautions

- (1) Always keep “safety” in mind when using this tool.
For proper use of this tool, sufficiently understand the safe use methods.
- (2) Please carefully read this instruction manual to understand proper usage before running, inspection, and maintenance of the tool.
- (3) Never remove any safety device such as a safety cover attached to the tool.
- (4) Do not remove or make illegible labels and indications affixed to the tool.
- (5) When not using the tool or during inspection or maintenance of the tool, shut off the air supply. And, do not touch the knife part (tip) with your bare hands.
- (6) If you notice any unusual movement or abnormality, stop using the tool.
- (7) Please inform us of any comments or questions you may have concerning safe use of our tools.

1-2. Application

This tool is designed to bind around various objects by using straps. Please do not use for purposes other than binding.

1-3. Work wear

When using this tool, wear protective equipment such as “protective glasses,” “protective mask,” “earplugs,” “leather gloves,” “protective footwear,” and a “helmet.”

In addition, make sure to wear long-sleeve outer wear and button the cuffs before use.

Be careful so that neckties and long hair do not become tangled in the tool.

1-4. Protective equipment



(1) Protective glasses

If a strongly bound strap is cut by scissors, a rebound strap may damage the eyes of an operator and make the operator blind. Never fail to wear protective glasses.

Also, dust attached to the tool may enter your eyes when cleaning the tool by air blow. Never fail to wear protective glasses.

(2) Protective mask

Turbine oil is contained in exhaust air from the tool. Never fail to wear a protective mask.

(3) Earplugs

It is recommended to wear earplugs in order to protect ears from running noise and exhaust noise from the tool.

(4) Protective gloves

For handling straps and sharp objects, wear protective gloves because touching them accidentally or carelessly may cause an incision wound.

(5) Safety shoes

Wear protective footwear (safety shoes) as heavy objects may drop and injure your feet.

(6) Helmet (Protective cap)

Wear a helmet or hard hat as the strap after cutting may snap back and injure your head.

1-5. Precautions

(1) Never touch the cutter part with your fingertips, because doing so may cause injury or severing of fingers.

(2) Vibration

- 3-axis composite vibration value is measured based on the description in “JIS B 7761-2:2004 (ISO 5349-2:2001)” using a vibration meter specified in “JIS B 7761-1:2004” and “JIS B 7761-3:2007 (ISO 5349-1:2001).”
- Depending on the total operating time, operators may be at risk. Get a physical checkup based on “Guidelines for Preventive Measures against Vibration Hazards in Work with Vibratory Tools other than Chain Saws,” etc., and take measures, safety and health education, and exercise based on the checkup result.

1-6. Inspection and repair

- (1) Remove the tool from the air hose or stop feeding compressed air before inspection or repair.
- (2) Check the attached portion of the tool to which a suspension (lifting component) is attached for looseness before operation.
- (3) Stop using the tool before inspection and repair any worn or damaged parts. Please contact us wherever necessary.

1-7. Disposal of the tool

“Steel,” “aluminum alloy,” “copper alloy,” “rubber,” or “plastics,” etc., is used for the tool. Please dispose of the tool according to the related ordinances etc., of the laws and regulations of the related national and local governments.

1-8. Inspection before work

- (1) Check the tool to confirm that there is no looseness or damage of the bolts before work every day. Clean the feed wheel for clogging by using a wire brush, etc.
- (2) Discharge the drain in the air supply piping.
- (3) Check if the air pressure is correct (0.6MPa) at the pipe end.
- (4) Check if oil level and drop amount of lubricant (turbine oil ISO VG32) in the lubricator are correct.
- (5) When connecting the air piping, do not push the valve button.

2. Specifications

	Strap used		Tightening force (0.6MPa)	Tightening speed with non-load	Weight	Air pressure	3-axis Composite vibration	Noise
	Width	Thickness						
	(mm)	(mm)						
MPLⅢ-19se	19	0.4~0.7	3500	100	3.6	0.4~0.6 ※ Note.1	1.39 ※ Note.2	92
MPLⅢ-16se	16		3000					
MPLⅢ-13se	13		2500					

Note.1) ◇ Minimum operating pressure changes according to the Thickness of strap and seal etc.

Note.2) ◇ 3-axis composite vibration value is measured based on JIS B 7761-2:2004 (ISO5349-2:2001). Daily vibration exposure limit: 5.0m/s² or less.

Note.3) ◇ Tightening force should be used within the elastic range of the strap.

3. Standard seal

The strength of seal portion varies greatly depending on the seal shape.

Select seals meeting the standards in the table below. In addition, our seals are formed to optimum dimensions.

	(mm)					
Model	W1	W2	H1	H2	L1	T
MPLⅢ-19se	19.7	21.4	2.8	6.0	22~25	0.6
MPLⅢ-16se	17.7	19.0	2.8	6.8	22~25	0.6
MPLⅢ-13se	14.2	15.4	2.8	6.0	22~25	0.6

Product name: OVERLAP SEAL

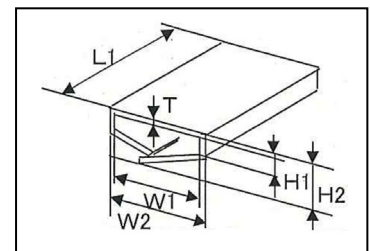

4. Pneumatic Information

4-1. Air source

As an air source of this tool, use a compressed air source of which the air pressure (source pressure) is 0.6MPa or more in the plant with a piping diameter of 3/8B (10A) or more, air flow rate of 1Nm³/min or more.

4-2. Used air component

The following components are recommended for this tool.

SL hose: WS18Z-06(3/8)×5m (Yokohama Rubber), Plug 30SH, 30SM, 30PH (Nitto Kohki)

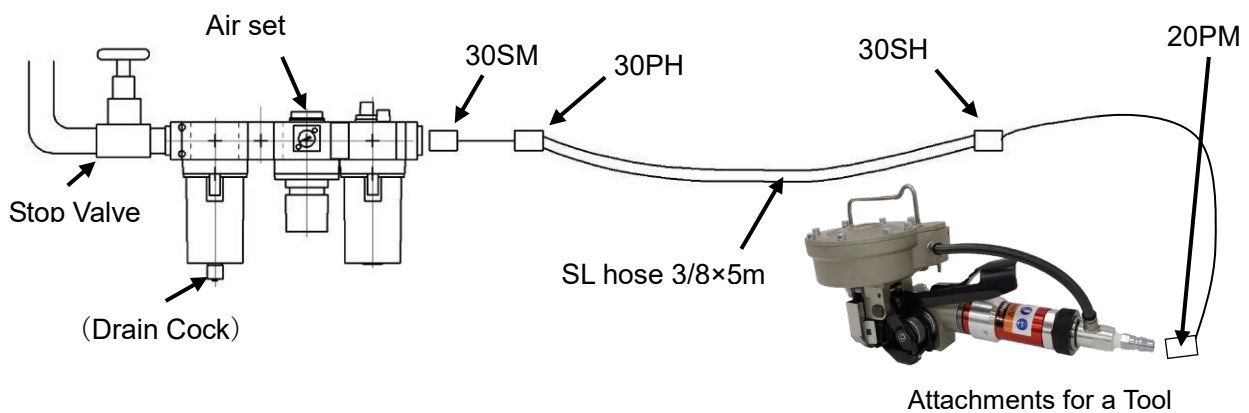

※Caution

If you use hoses other than the specified hoses, use hoses at 9.5 or more in inner diameter and 5m or less in length. Use of hoses other than the above-specified hoses will cause a drastic reduction in pressure during operation. Please pay attention.

4-3. Precautions for piping

- (1) Attach an air set of 3/8B or greater (filter, regulator, and lubricator) to the air source.
- (2) To prevent a reduction in pressure during operation, completely use parts of 3/8B or greater for piping.
- (3) An air motor is used for this tool. Be careful so as not to allow drain, rust, and pieces of seal tape in the piping to enter in the tool.
- (4) As the rotor of the air motor rotates at a high speed, if lubrication oil is insufficient in the air, the rotational number may drastically decrease or the tool may not start running. Always, pay attention to the level of lubrication oil (turbine oil: ISO VG32) of the lubricator, and adjust the oil drop amount so that 20 to 30 drops drip per minute.

5. Operating Instructions and Adjustments

5-1.Exterior

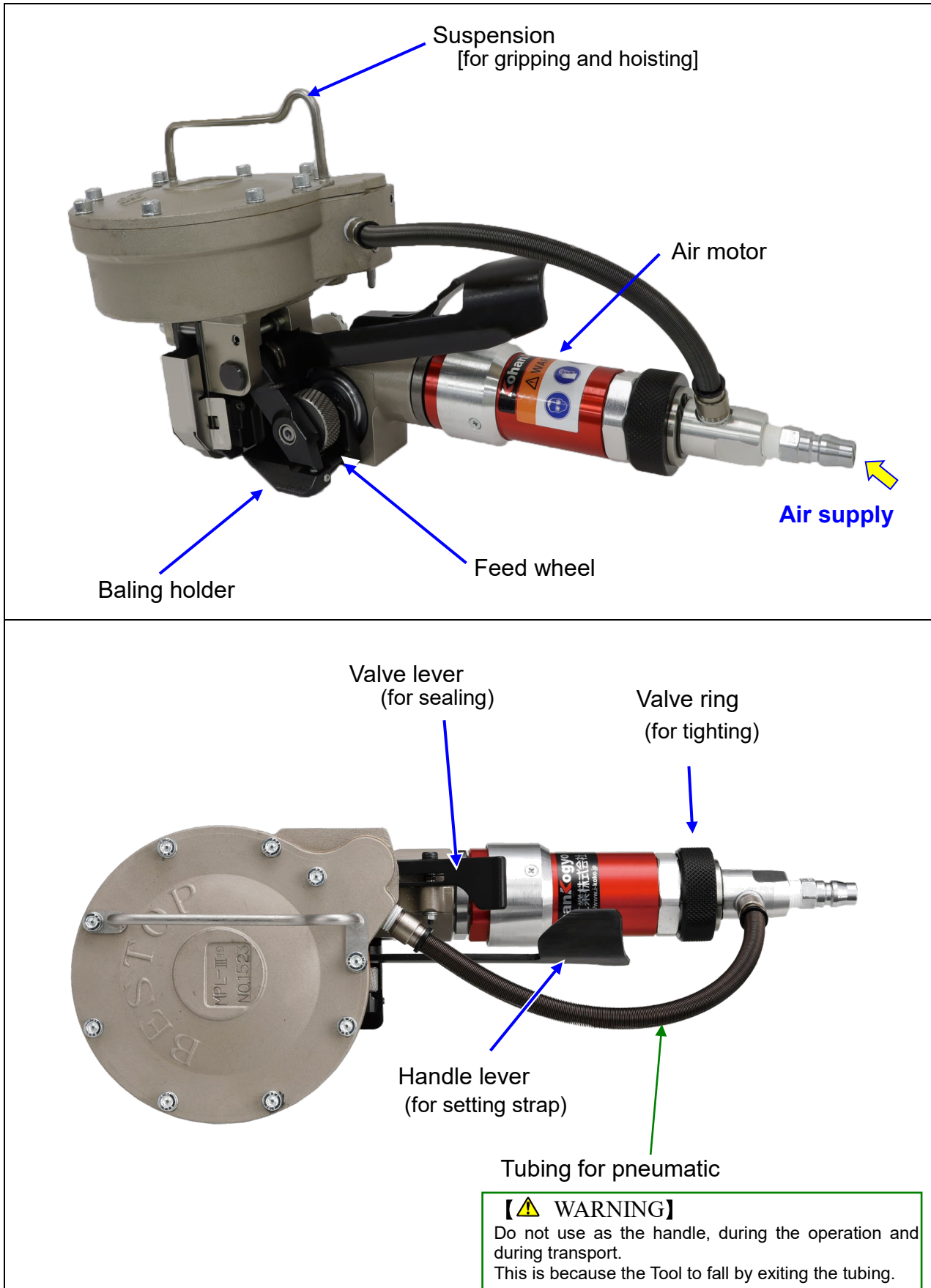

5-2. Operating method

1) How to pass a seal through a strap and bind strap



- ① Pass a strap through in a seal.
Then, wind the strap around an object.

【⚠ DANGER】
Wear protective gloves



- ② Pass the end of the strap through in the seal.
Then, fold the end of the strap under the seal
(folding length is approximately 50mm)

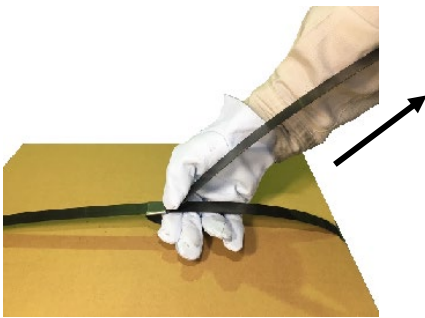

- ③ Tighten the strap passed through the seal in the arrow direction to remove excess looseness.
At that time, locate the seal at the approximately final position.

2) Strap setting



- (1) When grasp the handle lever with your right thumb and grasp the air motor with the other fingers, a gap between the feed wheel and the baling holder is formed.
(2) Insert the upper strap from the side in the gap between the baling holder and feed wheel. At this time, fully insert the strap until it horizontally hits the inner wall of the baling holder.
After insertion of the strap is completed, release the handle lever.

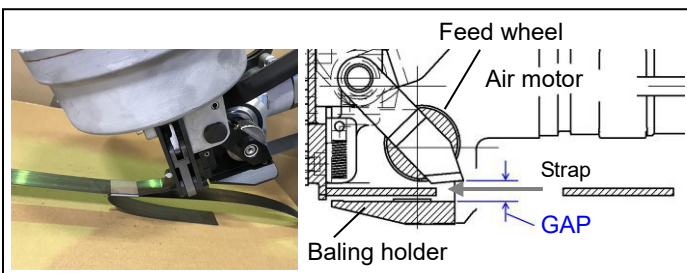

3) Tightening

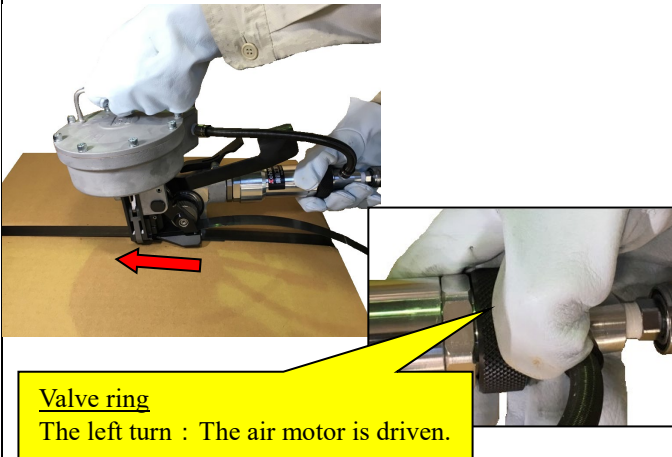

Valve ring
The left turn : The air motor is driven.

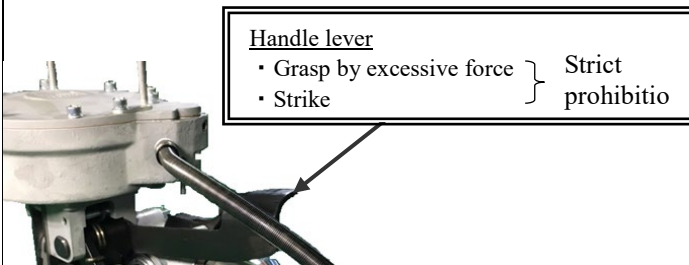

Handle lever

- Grasp by excessive force
- Strike

} Strict prohibitio

- (1) When the valve ring is turned left, the air motor is driven.
The strap is tensioned until binding tightly (then the air motor is stalled).
At this time, the tool moves forward in the arrow direction.
- (2) The forward movement of the tool stops while the strap is tightened.

【⚠ CAUTION】
Until the sealing in the next process is completed, do not return the valve ring. (This is because the strap is kept the state that tightened.)

【⚠ CAUTION】
When retry to bind by the reason such as a package is bound at wrong position, please cut the strap and retry to bind the new strap. When the tightening is completed by this tool, the strap is not loose even if the air motor stops. The operation that such as strike the handle lever or grasp by excessive force it is caused trouble of the tool. Therefore, please never operate the above.

4) Sealing and cutting

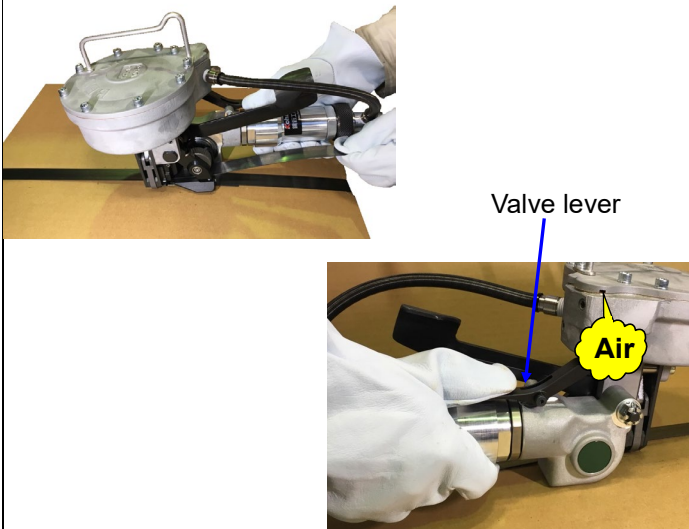

Valve lever

Air

- (1) Press the valve lever and perform the sealing and the cutting.
Until the sealing is completed, do not release the valve lever.
- (2) After the sealing and the cutting are completed, release your finger pressing the valve lever.
Then return the valve ring for the air motor to stop tightening.

【⚠ WARNING】
When release the valve lever the after cutting, air is spouted. (Refer to left figure)

5) Removal of tool

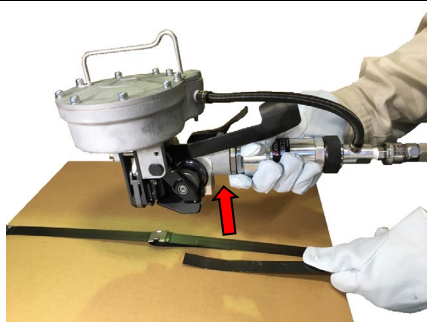

Move the tool in the arrow direction and remove from the strap. The binding is completed.



6. Exploded-view Drawing & Bill of Materials

6-1. Exploded-view Drawing : General View

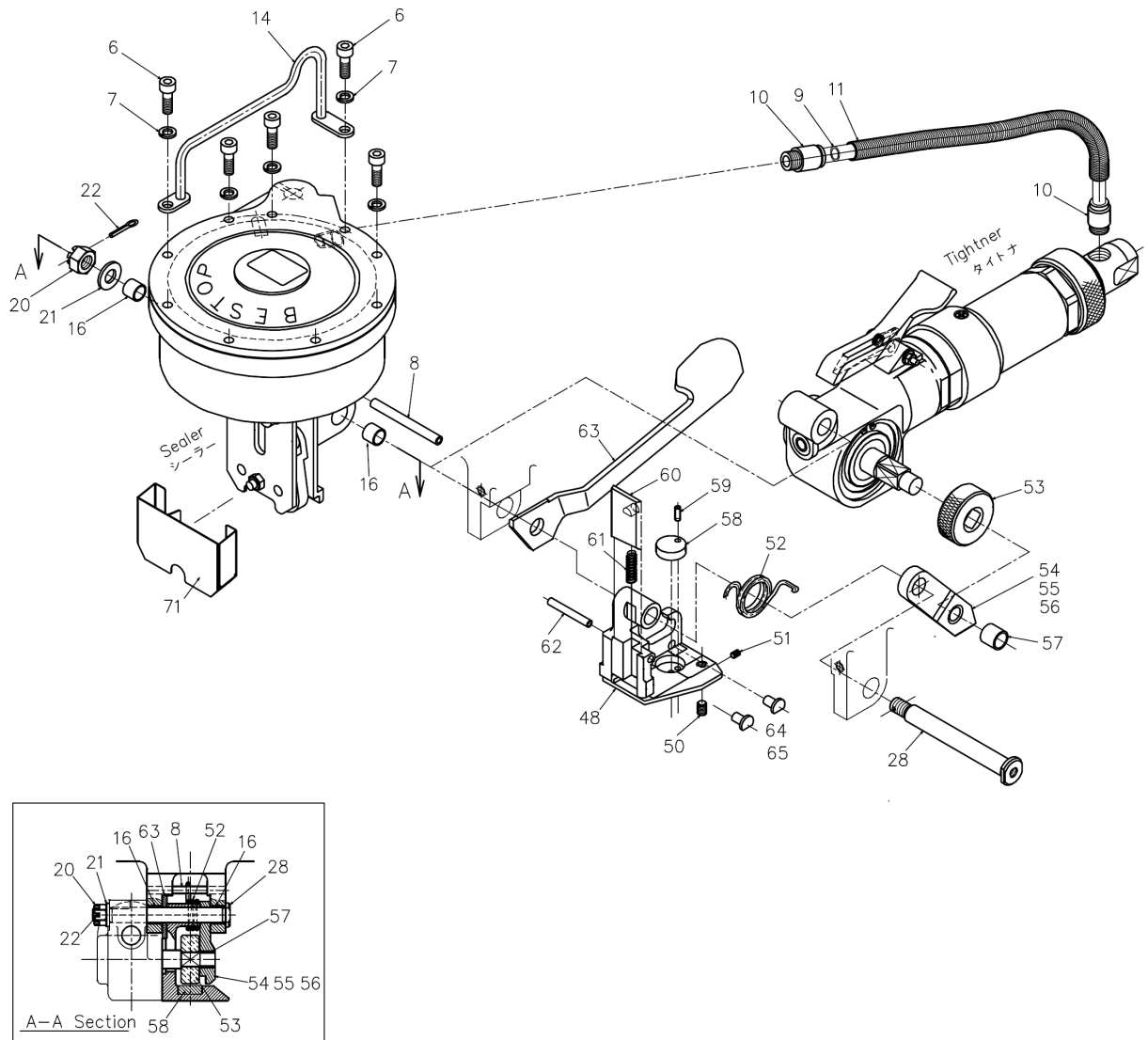

6-2. Bill of Materials : General View

KEY NO.	Parts Name	Parts No	DWG.No (Model No)	Q'ty			Expendable -Parts
				19	16	13	
6	Hexagon socket head cap screw	Purchase	(M5×15 Plated)	9	9	9	
7	Spring lock washer	Purchase	(M5 Plated)	9	9	9	
8	Spring pin	Purchase	(φ5×50)	1	1	1	
9	Soft nylon tube	Purchase	(TS0806B)	1	1	1	
10	Tube fitting connector with Hexagon socket head	Purchase	(POC8-02)	2	2	2	
11	Spring	1965	DK18377-1	1	1	1	
14	Suspension	1904	D85000-1	1	1	1	
16	Bush	Purchase	(MLE1010)	2	2	2	○
20	Hexagon castle nut(Low type)	Purchase	(M8 Plated)	1	1	1	
21	Plain washer	Purchase	(M8 Plated)	1	1	1	
22	Split pin	Purchase	(φ2×18 Plated)	1	1	1	
28	Hanger pin	1522	DK10110-1	1	1	1	
48	Baling holder	1940	B38030-1	1	1	1	
50	Hexagon socket set screw (flat point)	Purchase	(M6×8)	1	1	1	
51	Hexagon socket set screw (truncated cone point)	Purchase	(M4×5)	1	1	1	
52	Bailing holder spring	1946	E64622-1	1	1	1	
53	Feed wheel	1540	DK10116-1	1	1	1	○
54	Hanger (19)	15413	DK10117-3	1			
55	Hanger (16)	15412	DK10117-2		1		
56	Hanger (13)	15411	DK10117-1			1	
57	Bush	Purchase	(MLE0910)	1	1	1	○
58	Point	15441	EK2575-1	1	1	1	○
59	Spring pin	Purchase	(φ3×8 Plated)	1	1	1	
60	Shear knife	1551	EK10525-1	1	1	1	○
61	Shear spring	1552	EK9771-1	1	1	1	○
62	Spring pin	Purchase	(φ4×30 Plated)	1	1	1	
63	Handle lever	1966	DK18379-1	1	1	1	
64	Hoop guide (16)	15451	EK2576-1		2		
65	Hoop guide (13)	16041	EK2634-1			2	
71	Cover	1967	DK19665-1	1	1	1	

6-3 Exploded-view Drawing : Sealer

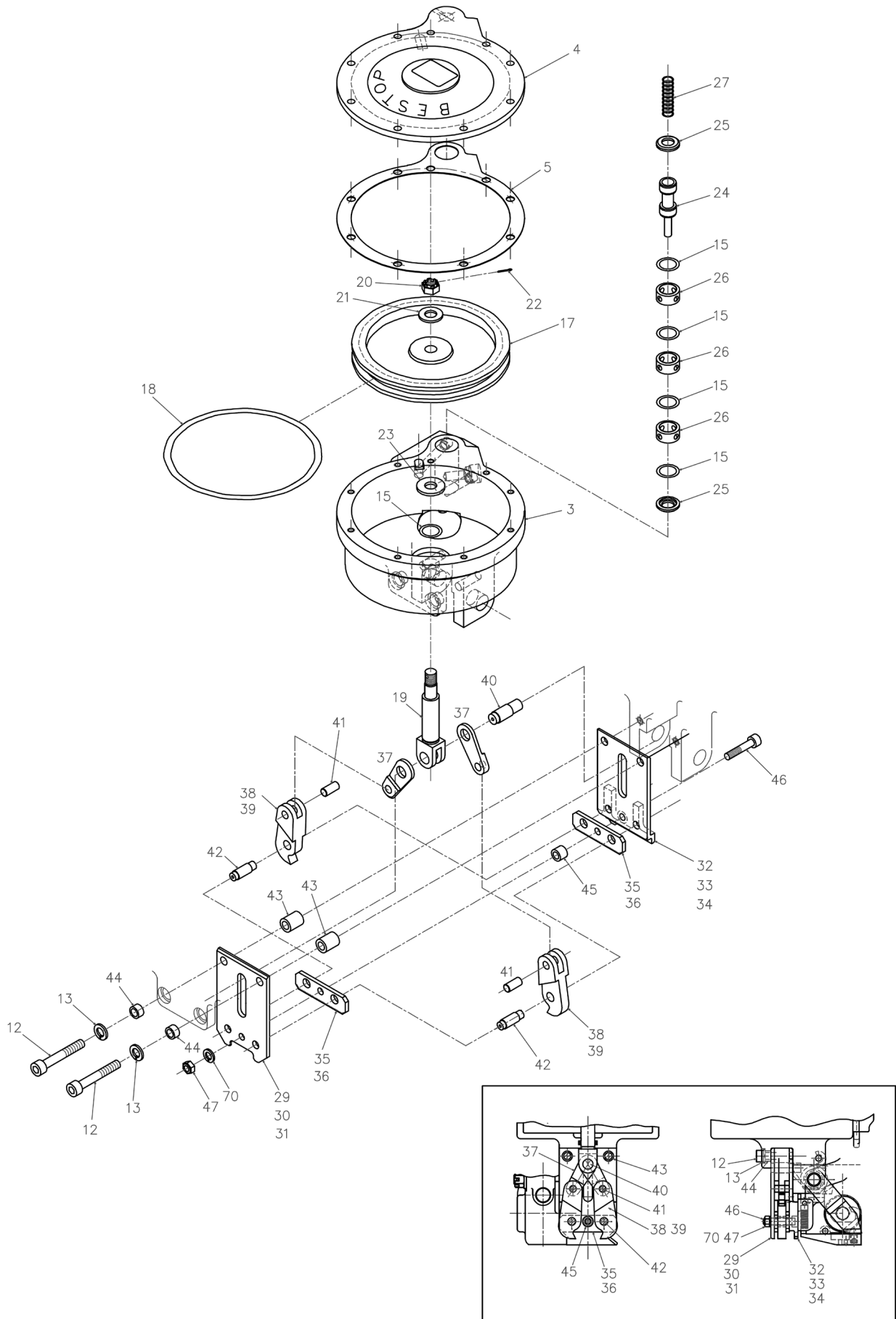

6-4. Bill of Materials : .Sealer

KEY NO.	Parts Name	Parts No	DWG.No (Model No)	Q'ty			Expendable -Parts
				19	16	13	
3	Cylinder body	19611	BK5057-1	1	1	1	
4	Cylinder cover	19621	CK13258-1	1	1	1	
5	Cylinder packing	19631	DK18614-1	1	1	1	
12	Hexagon socket head cap screw	Purchase	(M6×40Plated)	2	2	2	
13	Spring lock washer	Purchase	(M6 Plated)	2	2	2	
15	O-ring	Purchase	(P12)	5	5	5	○
17	Piston	1906	E64501-1	1	1	1	
18	O-ring	Purchase	(P102)	1	1	1	○
19	Piston rod	1511	DK10109-1	1	1	1	
20	Hexagon castle nut(Low type)	Purchase	(M8 Plated)	1	1	1	
21	Plain washer	Purchase	(M8 Plated)	1	1	1	
22	Split pin	Purchase	(φ2×18 Plated)	1	1	1	
23	Washer	1515	EK10451-1	1	1	1	
24	Spool valve rod	1964	EK20059-1	1	1	1	
25	Seal cage (A)	1517	EK10517-1	2	2	2	
26	Seal cage (B)	1903	E64503-1	3	3	3	
27	Spool valve spring	1520	EK9767-1	1	1	1	
29	Outside plate (19)	1524	DK10112-1	1			○
30	Outside plate (16)	1523	DK10111-1		1		○
31	Outside plate (13)	1600	DK10158-1			1	○
32	Inside plate (19)	1938	C34032-1	1			○
33	Inside plate (16)	1525	C34051-1		1		○
34	Inside plate (13)	1601	C34052-1			1	○
35	Anvil (19)	1530	EK10463-1	2			○
36	Anvil (16)(13)	1529	EK10519-1		2	2	○
37	Link	1531	EK10521-1	2	2	2	○
38	Cutter(16)(19)	1532	DK10115-1	2	2		○
39	Cutter (13)	1602	DK10155-1			2	○
40	Piston rod pin	1533	EK8758-1	1	1	1	○
41	Link pin	1534	EK8755-1	2	2	2	○

KEY NO.	Parts Name	Parts No	DWG.No (Model No)	Q'ty			Expendable -Parts
				19	16	13	
42	Cutter pin	1535	EK8754-1	2	2	2	○
43	Spacer (1)	1536	EK10453-1	2	2	2	
44	Spacer (2)	1947	E64700-1	2	2	2	
45	Spacer (3)	1527	EK10518-1	1	1	1	
46	Hexagon socket head cap screw	Purchase	(M5×25Plated)	1	1	1	
47	U nut	Purchase	(M5 Plated)	1	1	1	
70	Spring Washer	Purchase	(M5 Plated)	1	1	1	

6-5. Exploded-view Drawing : Tightener

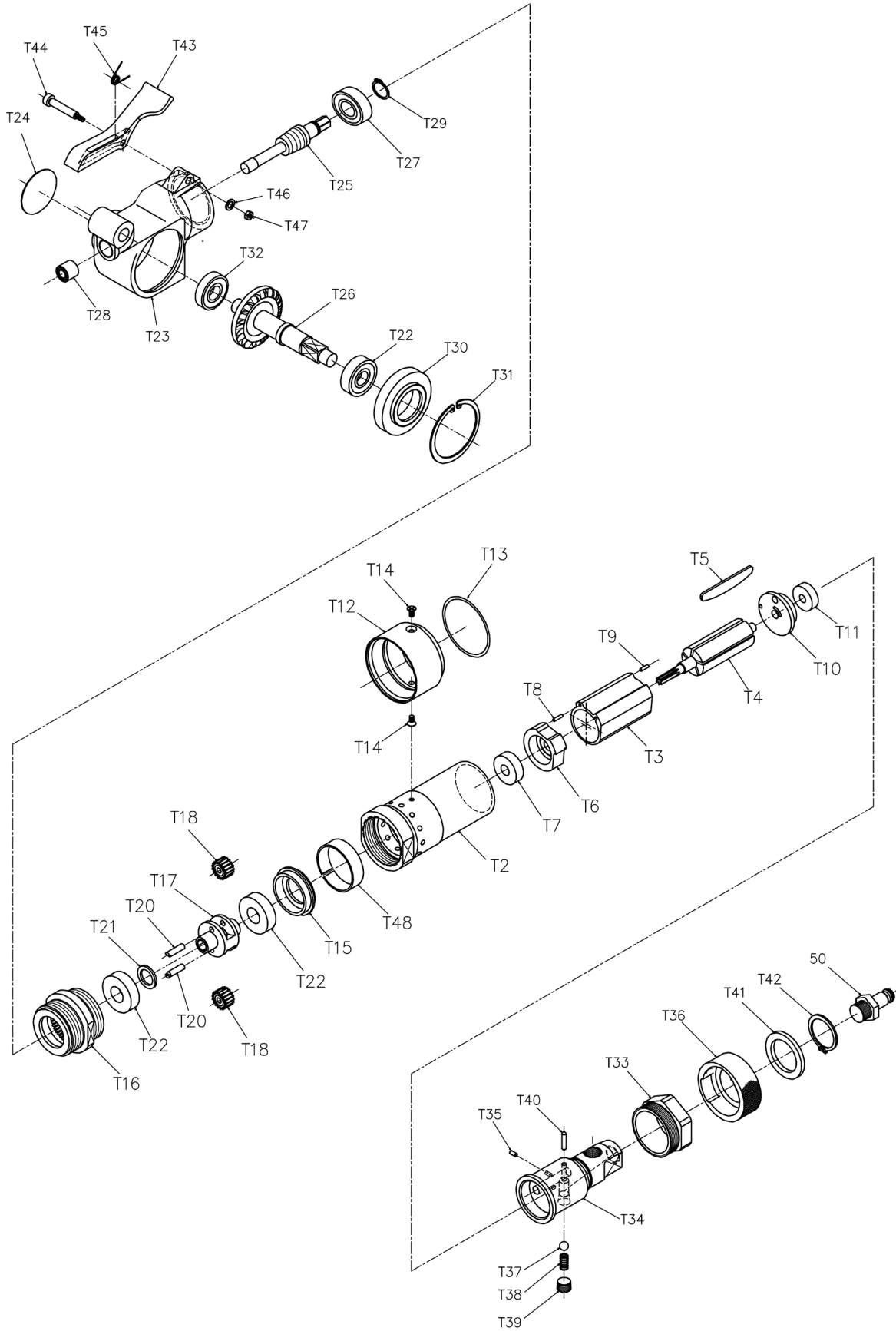

KEY NO.	Parts Name	Parts No	DWG.No (Model No)	Q'ty			Expendable -Parts
				19	16	13	
T2	Motor case	1951	DK18262-1	1	1	1	
T3	Cylinder	01181	CK12522-1	1	1	1	
T4	Rotor	1952	DK18263-1	1	1	1	
T5-1	Vane Type:19	1953	EK21507-1	5	/	/	
T5-2	Vane Type:16	19532	EK21508-1	/	5	/	
T5-3	Vane Type:13	19533	EK21509-1	/	/	5	
T6	Front cylinder cover	01171	DK18057-1	1	1	1	
T7	Deep groove ball bearing	Purchase	(#608ZZ)	1	1	1	○
T8	Needle pin (Heat treatment)	Purchase	($\phi 2 \times 7.8$)	1	1	1	
T9	Needle pin (Heat treatment)	Purchase	($\phi 2 \times 6.8$)	1	1	1	
T10	Rear cylinder cover	01241	DK18058-1	1	1	1	
T11	Deep groove ball bearing	Purchase	(#626ZZ)	1	1	1	○
T12	Exhaust Cover	1954	EK20055-1	1	1	1	
T13	O-ring	Purchase	(S42)	1	1	1	
T14	Countersunk head screw	Purchase	(M3×8 Plated)	2	2	2	
T15	Bearing box for 1st idle frame	1955	EK20056-1	1	1	1	
T16	Internal gear	1576	DK9077-1	1	1	1	
T17	Idle frame	1578	DK9427-1	1	1	1	
T18	Idle gear (with Needle bearing)	1579	EK8885-1	2	2	2	
T20	Idle gear shaft	1581	EK8888-1	2	2	2	
T21	Idle frame wrapper	1582	EK8889-1	1	1	1	
T22	Deep groove ball bearing	Purchase	(#6001ZZ)	3	3	3	○
T23	Gear case	1956	CK12865-1	1	1	1	
T24	Plug	1127	EK10284-1	1	1	1	
T25	Spiroid pinion	1586	DK9428-1	1	1	1	
T26	Spiroid gear	1587	DK11298-1	1	1	1	
T27	Deep groove ball bearing	Purchase	(#6300ZZ)	1	1	1	○
T28	Needle bearing	Purchase	(BK0810)	1	1	1	○
T29	C-type retaining ring for shaft	Purchase	(10)	1	1	1	
T30	Bearing holder	1591	DK10267-1	1	1	1	
T31	C-type retaining ring for bore	Purchase	(48)	1	1	1	
T32	Deep groove ball bearing	Purchase	(#6000ZZ)	1	1	1	○
T33	Adapter sleeve	17751	E59450-1	1	1	1	

KEY NO.	Parts Name	Parts No	DWG.No (Model No)	Q'ty			Expendable -Parts
				19	16	13	
T34	Valve body	1957	DK18264-1	1	1	1	
T35	Spring pin	Purchase	(φ2.5×8 Plated)	1	1	1	
T36	Valve ring	1958	DK18265-1	1	1	1	
T37	Urethane ball	15961	(φ7.54)	1	1	1	○
T38	Rotary valve spring	1597	EK8892-1	1	1	1	○
T39	Hexagon socket head plug	Purchase	(1/8 Plated)	1	1	1	
T40	Valve rod	15991	EK20196-1	1	1	1	
T41	Color	Purchase	(WSSS35-25-3)	1	1	1	
T42	C-type retaining ring for shaft	Purchase	(24)	1	1	1	
T43	Valve lever	1959	DK18266-1	1	1	1	
T44	Outer screw type stripper bolt	Purchase	(GMSB5-25)	1	1	1	
T45	Torsion spring	1937	E64506-1	1	1	1	○
T46	Nord-lock washer	Purchase	(M3 NL3DP)	1	1	1	
T47	Hexagon nut	Purchase	(M3 Plated)	1	1	1	
T48	Silencer	1960	EK20136-1	1	1	1	
T50	Coupler(Plug)	Purchase	(20PM)	1	1	1	

7. Troubleshooting

Trouble condition	Cause	Actions to take
1. Malfunction	1. Low air pressure	1. Check to see whether the pressure gauge attached to the pressure reducing valve indicates the correct pressure. If the pressure is too low, make adjustment to the correct pressure.
	2. Insufficient air pressure (Hose size : 3/8B×5m Flow : Max1.1Nm ³ /min)	1. Check to see if the size of the hose supplying air to the tool is correct. If the size is not correct, replace the hose.
		2. Remove the main body and blow off compressed air through the air hose only, and check to see if the flow rate to the hose is correct. At this time hold the end of the hose firmly. Replace the rubber hose if the air supply amount is small due to the internal diameter having become small due to oil etc.
		3. Check each operation to see if the valve can be switched by lever operation.
	4. Check each part for air leakage and take action. If air leaks, it is considered that the packing is broken or tightening is poor, then repair is required.	
	3. Insufficient lubricant	1. If lubricator drop of the air set (F.R.L combination) is insufficiently adjusted, correct it. And inject some drops of turbine oil from the air supply port on the main body.

Trouble condition	Cause	Actions to take
1. Malfunction	4. Looseness of joint screw	1. Looseness of the following screws or bolts results in a start failure, therefore, check and tighten them. <ul style="list-style-type: none"> ●Bolts for side plates and links, etc., on the sealer part ●Mounting bolts for the cylinder and cover. ●Motor mounting bolts for the tightener part, mounting bolts for the main shaft hanger unit.
	5. If there is no improvement even by the above operation	1. Internal abnormality is considered. Therefore, contact our distributor or our company. <Example> ~Cylinder-related~ <ul style="list-style-type: none"> ●Malfunction due to rust (caused by inflow of moisture etc.), foreign substance. etc., in cylinder. ●Breakage or wear of piston rod pin, nut, O-ring and piston, etc. ~Valve unit-related~ <ul style="list-style-type: none"> ●Air leakage or malfunction due to foreign substance etc., on spool valve rod ●Breakage or wear of lantern ring, spring for spool valve rod, O-ring, etc. ~Motor-related~ <ul style="list-style-type: none"> ●Rotation failure to rust (caused by inflow of moisture etc.)or foreign substance etc ., in air motor. ●Breakage, wear and adherence of internal parts such as Rotor, Gear, Bearing etc. ●Misalignment between Cylinder and Nock pin for cylinder cover. ~Gear case-related~ <ul style="list-style-type: none"> ●Breakage or wear of gear and bearing, etc.

Trouble condition	Cause	Actions to take
2. Strap insertion failure	1. Baling holder opening shortage	1. Check to see if handle lever is not bent.
3. Insufficient tightening force	1. When air supply pressure and supply amount are insufficient	1. For inspection of air amount, check to see if the difference in pressure between when the tightener is stopped and when idling has not significantly decreased. If it has decreased, the flow rate is insufficient.
		2. If the distance from the air set(F.R.L combination) to Tightener is too long and they are connected with an air hose for piping, the air pressure is reduced. Therefore the distance should be 5 m or less.
		3. Check to see that there are no air leaks etc., from the main body. If there are air leaks etc., tighten screw etc. additionally. Contact our distributor or our company because disassembly will be required in case of defective internal parts.
	2. Malfunction by feed wheel	1. Inspect the feed wheel for clogging. Remove the feed wheel from the tightener. Then clean the feed wheel by contacting a wire brush. Periodic cleaning of the feed wheel is effective. If it is worn or damaged, etc., replace with a new one.
		2. Inspect if the clearance between the point and the feed wheel open correctly. Adjust the clearance by the adjustment screw on the rear of the baling holder.
		3. Inspect the blade edge of the feed wheel. Replace any worn or damaged blades with new ones.
		4. Check carefully if the baling holder is not significantly deformed or cracked.

Trouble condition	Cause	Actions to take
3. Insufficient tightening force	3. Air motor does not work	1. Check to see if there is abnormal noise or low rotating noise of air motor. dust may be contained in the air motor. Therefore, disassembly or maintenance is immediately required.
		2. If exhaust noise becomes large at the completion of tightening (motor load stop), the vanes may be excessively worn at the sliding surface. Therefore, the vanes etc. must be replaced.
4. Strap cutting failure	1. Air pressure decreases.	1. Reduction in air pressure causes a cutting failure of the band. Check that the air pressure has been adjusted to a predetermined pressure.
	2. Blade edge of shear knife is worn or damaged.	2. Shearing force is supplied from sealing cylinder. Refer to sealing operation. 1. Inspect the blade edge of the shear knife. If it is worn or damaged, replace it with new one.
5. Poor sealing including poor strength of sealed part	1. Low air pressure	1. Low air pressure will cause a cutting failure of the straps. Check to see if the air pressure is as specified.
	2. Wear or chip of cutter	1. If the depth and height of the notch are insufficient, resulting in poor sealing, replace it. After replacement, confirm that the depth and height of the notch are normal by testing. It is recommended to keep new-product notch samples for notch confirmation use after maintenance.
	3. Wear spacer	
	4. Wear or break of cutter pin, link pin or piston rod pin	
	5. Wear or break of side plate	1. Conduct seal sampling inspections to confirm conformity with the shape dimensions
6. Wrong shape of seal		

Trouble condition	Cause	Actions to take
5. Poor sealing including poor strength of sealed part	7. Nut of piston rod becoming loose	1. Internal abnormality is considered. Contact our distributor or our company.
	8. Wear or break O-ring of piston	
	9. Wear or break O-ring for the sealer valve	
	10. Wear or break piston and cylinder	
	11. A foreign body being clogged between piston and cylinder	
6. Other	1. Abnormal noise or heat is generated	1. If any abnormal noise or heat is generated during operation, immediately stop operation and inspect each part.

8. Pneumatic circuit

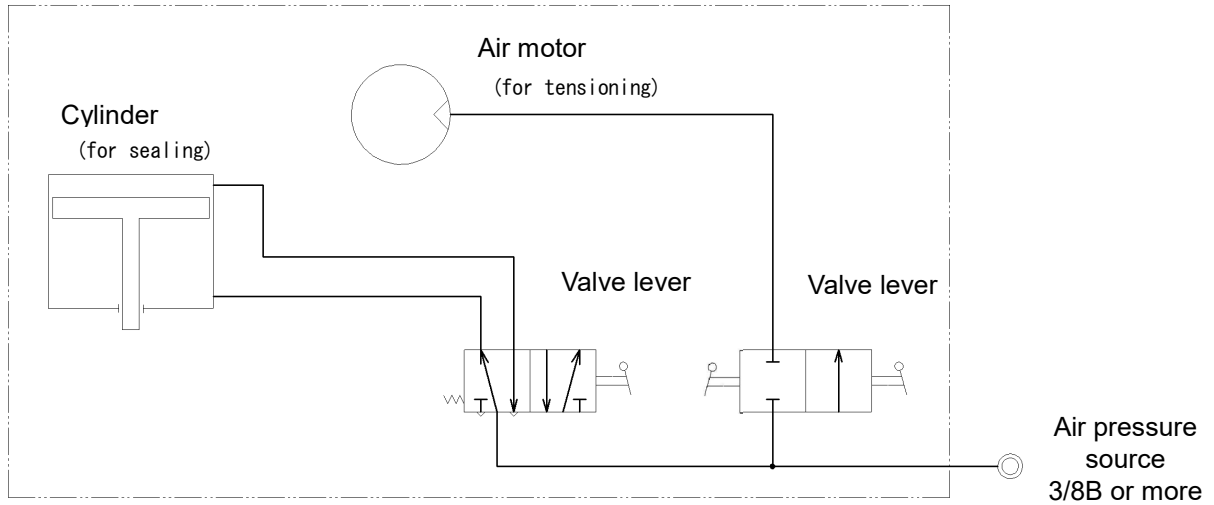

Operational description

1. When turning the valve ring for the air motor of the tool, the valve for the air motor is switched, the air motor rotates to tighten the strap.
2. When pressing the valve lever for the cylinder of the tool, the valve for the sealer is switched, the cylinder for the sealer descends to seal and shear the seal.

KohanKogyo

KOHAN KOGYO CO., LTD.

■帯鋼機器営業部門

東京営業部 〒141-0022 東京都品川区東五反田 18 番 1 号 (大崎フォレストビルディング 19F)
Tel. 03-4531-6891、FAX. 03-3280-8162

大阪営業部 〒541-0041 大阪市中央区北浜 4 丁目 7 番 19 号 (住友ビル 3 号館 4F)
Tel. 06-6223-4680、FAX. 06-6223-4681

下松営業部 〒744-0011 山口県下松市西豊井 1394 番地
Tel. 0833-43-1824、FAX. 0833-44-0964

Tokyo Sales Department Osaki Forest Building, 2-18-1 Higashi-Gotanda Shinagawa-Ku,
Tokyo, 141-0022, Japan, Tel. +81-3-4531-6891

Osaka Sales Department Sumitomo Building 3Go-Kan, 4-7-19 Kitahama, Chuo-Ku,
Osaka, 541-0041, Japan, Tel. +81-6-6223-4680

Kudamatsu Sales Department 1394 Nishitoyoi, Kudamatsu, Yamaguchi,
744-0002, Japan, Tel. +81-833-43-1824

■機 器 工 場 〒744-0011 山口県下松市西豊井 1394 番地 Tel.0833-43-2640
Machinery Works 1394 Nishitoyoi, Kudamatsu, Yamaguchi 744-0011, Japan
Tel. +81-833-43-2640

■海外営業所 / 現地法人

中 国 / China Branch

SHANGHAI TOYO KOHAN TRADING CO., LTD. "Kohan Kogyo" Division
Room 2701, Shenggao International Building, No137, XianXia Road Shanghai 200051, China
Tel. +86-21-6259-1708, Fax. +86-21-6270-3308

台 湾 / Taiwan Branch

KOHAN KOGYO CO., LTD. TAIWAN BRANCH (JAPAN)
No. 26, Ln. 76, Shepi Rd., Fengyuan Dist., Taichung City 420077, Taiwan (R.O.C.)
Tel. +886-4-2259-2850, Fax. +886-4-2259-2851

韓 国 / Korea Branch

KOHAN KOGYO KOREA CO., LTD.
No.115・215, 132-Dong, Busan T-PLEX, 41, Yulongdanji-1Ro (Daejeo-2Dong), Gangseo-gu, Busan,
46721, Korea,
Tel. +82-51-710-6342, Fax. +82-70-8282-0526