

**INSTRUCTION MANUAL**  
**FOR**  
**BESTOP STRAPPING TOOL**  
**MODEL MPH-D**



**Kohankogyo**  
KOHAN KOGYO CO., LTD.

Rev.3H

# — CONTENTS —

1. Safety Instructions	-----
1-1. General precautions	
1-2. Application	
1-3. Work wear	
1-4. Protective equipment	
1-5. Precautions	
1-6. Inspection and repair	
1-7. Disposal of the tool	
1-8. Inspection before work	
1-9. Warning Labels	
2. Specifications	-----
3. Standard seal	-----
4. Pneumatic Information	-----
4-1. Air source	
4-2. Used air component	
4-3. Precautions for piping	
5. Operating Instructions and Adjustments	-----
5-1. Exterior	
5-2. Operating method	
5-3. Adjustment	
5-4. Operating suggestions	
6. Exploded-view Drawing & Bill of Materials	-----
6-1. Exploded-view Drawing : Sealing mechanism	
6-2. Bill of Materials : Sealing mechanism	
6-3. Exploded-view Drawing : Locking mechanism • Piston • Hook	
6-4. Bill of Materials : Locking mechanism • Piston • Hook	
6-5. Exploded-view Drawing : Gear Case • Baling Holder	
6-6. Bill of Materials : Gear Case • Baling Holder	
6-7. Exploded-view Drawing : Air Motor	
6-8. Bill of Materials : Air Motor	
6-9. Exploded-view Drawing : Option	
6-10. Bill of Materials : Option	
7. Troubleshooting	-----
8. Air Logic and Diagram	-----

## Safety instructions

- Before starting operation, maintenance or inspection of this device, carefully read this instruction manual.
- Contents shown in this instruction manual are described to assist safe operation and prevent danger and the damage to you and other people beforehand.
- For individual operation, observe the contents of this instruction manual. Although this device is designed and manufactured in consideration of safety, failure to follow this precaution may cause serious personal accidents such as the death or serious injuries.
- Before starting individual operation, understand the knowledge of the equipment, safety information, and all contents of this instruction manual.
- In this instruction manual, the ranks of the safety Precautions have been divided with “Danger”, “Warning”, “Caution” ,and “Notes”.

**【  DANGER】**

Indicates a hazardous situation which, if not avoided, will result in death or serious bodily injury.

**【  WARNING】**

Indicates a hazardous or potentially dangerous situation which, if not avoided, could result in death or serious bodily injury.

**【  CAUTION】**

Indicates a hazardous or potentially dangerous situation which, if not avoided, could result in minor or moderate bodily injury or property damage.

**【※ Notes】**

Indicates that mishandling may cause an operational mistake.

Even if the matter described to “Caution”, there is the possibility to relate to an important result according to the situation. Observe all safety precautions because the important contents have been described.

## 1. Safety Instructions

### 1-1. General precautions

(1) Always keep “safety” in mind when using this tool.

For proper use of this tool, sufficiently understand the safe use methods.

(2) Please carefully read this instruction manual to understand proper usage before running, inspection, and maintenance of the tool.



(3) Never remove any safety device such as a safety cover attached to the tool.

(4) Do not remove or make illegible labels and indications affixed to the tool.

(5) When not using the tool or during inspection or maintenance of the tool, shut off the air supply. And, do not touch the knife part (tip) with your bare hands.

(6) If you notice any unusual movement or abnormality, stop using the tool.

(7) Please inform us of any comments or questions you may have concerning safe use of our tools.

### 1-2. Application

This tool is designed to bind around various objects by using straps. Please do not use for purposes other than binding.

### 1-3. Work wear

When using this tool, wear protective equipment such as “protective glasses,” “protective mask,” “earplugs,” “leather gloves,” “protective footwear,” and a “helmet.”

In addition, make sure to wear long-sleeve outer wear and button the cuffs before use. Be careful so that neckties and long hair do not become tangled in the tool.

### 1-4. Protective equipment



#### (1) Protective glasses

If a strongly bound strap is cut by scissors, a rebound strap may damage the eyes of an operator and make the operator blind. Never fail to wear protective glasses.

Also, dust attached to the tool may enter your eyes when cleaning the tool by air blow. Never fail to wear protective glasses.

#### (2) Protective mask

Turbine oil is contained in exhaust air from the tool. Never fail to wear a protective mask.

#### (3) Earplugs

It is recommended to wear earplugs in order to protect ears from running noise and exhaust noise from the tool.

#### (4) Protective gloves

For handling straps and sharp objects, wear protective gloves because touching them accidentally or carelessly may cause an incision wound.

(5) Safety shoes

Wear protective footwear (safety shoes) as heavy objects may drop and injure your feet.

(6) Helmet (Protective cap)

Wear a helmet or hard hat as the strap after cutting may snap back and injure your head.

1-5. Precautions

(1) Never touch the cutter part with your fingertips, because doing so may cause injury or severing of fingers.

(2) Vibration

- 3-axis composite vibration value is measured based on the description in “JIS B 7761-2:2004 (ISO 5349-2:2001)” using a vibration meter specified in “JIS B 7761-1:2004” and “JIS B 7761-3:2007 (ISO 5349-1:2001).”
- Depending on the total operating time, operators may be at risk. Get a physical checkup based on “Guidelines for Preventive Measures against Vibration Hazards in Work with Vibratory Tools other than Chain Saws,” etc., and take measures, safety and health education, and exercise based on the checkup result.

(3) Rotation

During rotation of the feed wheel when tightening straps, do not touch or stick fingers into the feed wheel, otherwise, fingers may be entangled.

1-6. Inspection and repair

- (1) Remove the tool from the air hose or stop feeding compressed air before inspection or repair.
- (2) Check the attached portion of the tool to which a suspension (lifting component) is attached for looseness before operation.
- (3) Stop using the tool before inspection and repair any worn or damaged parts. Please contact us wherever necessary.

1-7. Disposal of the tool

“Steel,” “aluminum alloy,” “copper alloy,” “rubber,” or “plastics,” etc., is used for the tool. Please dispose of the tool according to the related ordinances etc., of the laws and regulations of the related national and local governments.

1-8. Inspection before work

- (1) Make sure the link cover is not damaged and the link of sealer is not uncovered. If the link cover is damaged, please purchase the link cover from us and replace it before using.



- (2) Check the tool to confirm that there is no looseness or damage of the bolts before work every day. Clean the feed wheel for clogging by using a wire brush, etc.
- (3) Discharge the drain in the air supply piping.
- (4) Check if the air pressure is correct (0.6MPa) at the pipe end.
- (5) Check if oil level and drop amount of lubricant (turbine oil ISO VG32) in the lubricator are correct.

- (6) Air piping connection is done make sure that the tightening is in a stopped state. Be careful when you connect the air in the state valve rod for motor is pushed up, it starts to turn the feed wheel. And In addition, make sure that the valve rod for sealer is down and the sealer is open.

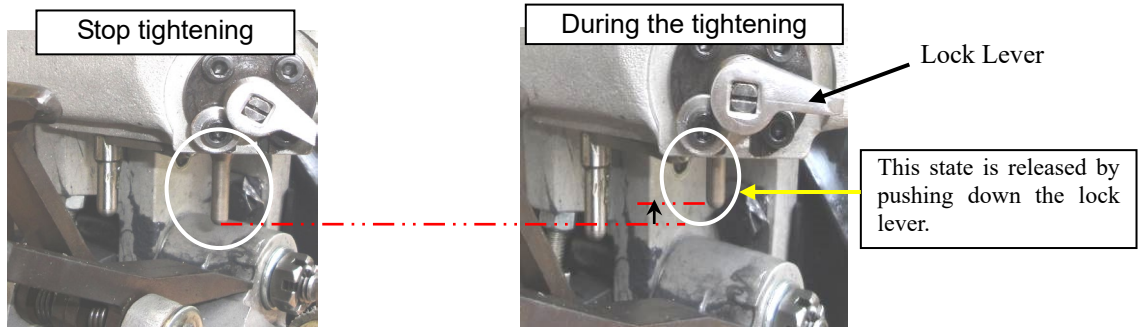

- (7) When connecting the air piping, hold down the cylinder body. Please note that the bearing holder will be lifted when air is connected.

### 1-9 Warning Label

The following indicates the locations of the warning labels. Be sure to confirm the locations before using the Product.

#### Label Locations



- (1) Warning labels indicating important precautions are on the Product. The supervisors and Workers shall fully understand the meanings of these warning labels for safe operation in a manner that will not cause damage to the product.
- (2) Do not tear off or damage the warning labels and do not clean them using solvent.
- (3) If the warning labels attached to the Product have become illegible, damaged or peeled, purchase replacement labels from Kohan Kogyo and replace them in accordance with the label layout drawing.
- (4) If any part with a warning label is replaced, attach a new warning label to the new part in the same manner as before.

## 2. Specifications

	Strap used		Tightening force (0.6MPa)	Weight (kg)	Applicable seal length (mm)	Air Pressure (MPa)	3-axis composite vibration (m/s <sup>2</sup> )	Noise (dB)
	Width (mm)	Thickness (mm)						
MPH-32Dse	32	0.5~1.2	7840N	15.4	50	0.6 ※Note.1	7.5 ※ Note.2	110

Note.1) ◇ Minimum operating pressure changes according to the Thickness of strap and seal etc.

Note.2) ◇3-axis composite vibration value is measured based on JIS B 7761-2:2004 (ISO5349-2:2001).

When the daily vibration exposure limit value is assumed to be 5.0m/s<sup>2</sup>, the number of possible binding times per day (8 Hr) is about 1,400 times.

Note.3) ◇Tightening force should be used within the elastic range of the strap.

## 3. Standard seal

The strength of seal portion varies greatly depending on the seal shape.

Select seals meeting the standards in the table below. In addition, our seals are formed to optimum dimensions.

Model	W1	W2	H1	H2	L1	T
MPH-32Dse	33.9	35.7	3.7	9.7	50.0	0.9

(mm)

Product name: OVERLAP SEAL

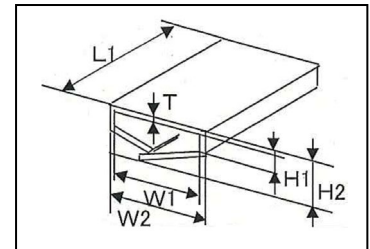

## 4. Pneumatic Information

### 4-1. Air source

As an air source of this tool, use a compressed air source of which the air pressure (source pressure) is 0.6MPa or more in the plant with a piping diameter of 3/8B (10A) or more, air flow rate of 1Nm<sup>3</sup>/min or more.

### 4-2. Used air component

The following components are recommended for this tool.

SL hose: WS18Z-06(3/8)×5m (Yokohama Rubber), Plug 30SH, 30SM, 30PH (Nitto Kohki)

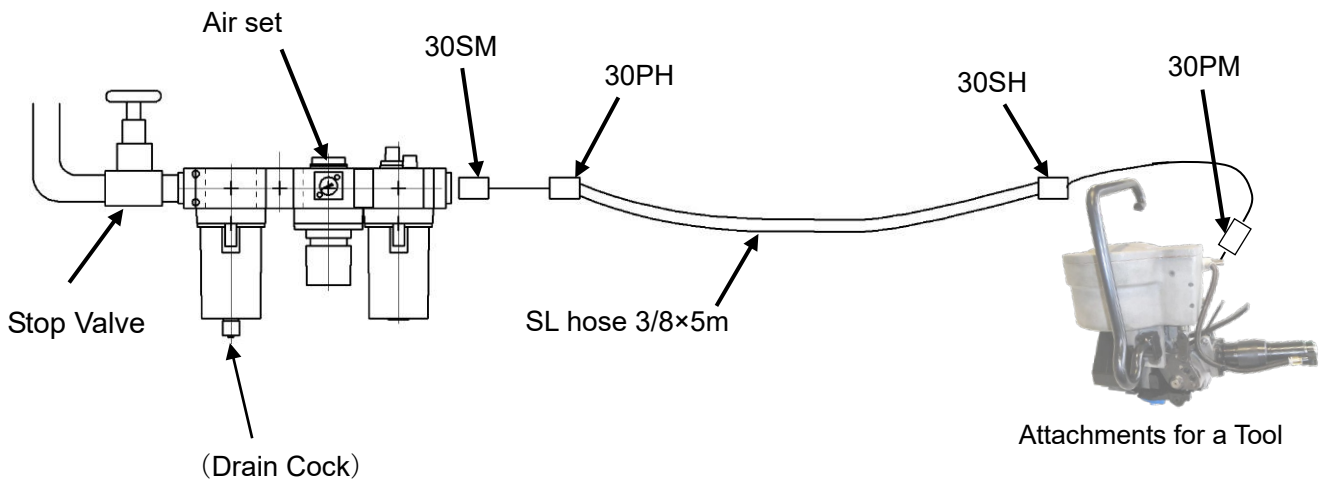

### ※Caution

If you use hoses other than the specified hoses, use hoses at 9.5 or more in inner diameter and 5m or less in length. Use of hoses other than the above-specified hoses will cause a drastic reduction in pressure during operation. Please pay attention.

### 4-3. Precautions for piping

- (1) Attach an air set of 3/8B or greater (filter, regulator, and lubricator) to the air source.
- (2) To prevent a reduction in pressure during operation, completely use parts of 3/8B or greater for piping.
- (3) An air motor is used for this tool. Be careful so as not to allow drain, rust, and pieces of seal tape in the piping to enter in the tool.
- (4) As the rotor of the air motor rotates at a high speed, if lubrication oil is insufficient in the air, the rotational number may drastically decrease or the tool may not start running. Always, pay attention to the level of lubrication oil (turbine oil: ISO VG32) of the lubricator, and adjust the oil drop amount so that 20 to 30 drops drip per minute.

## 5. Operating Instructions and Adjustments

### 5-1. Exterior

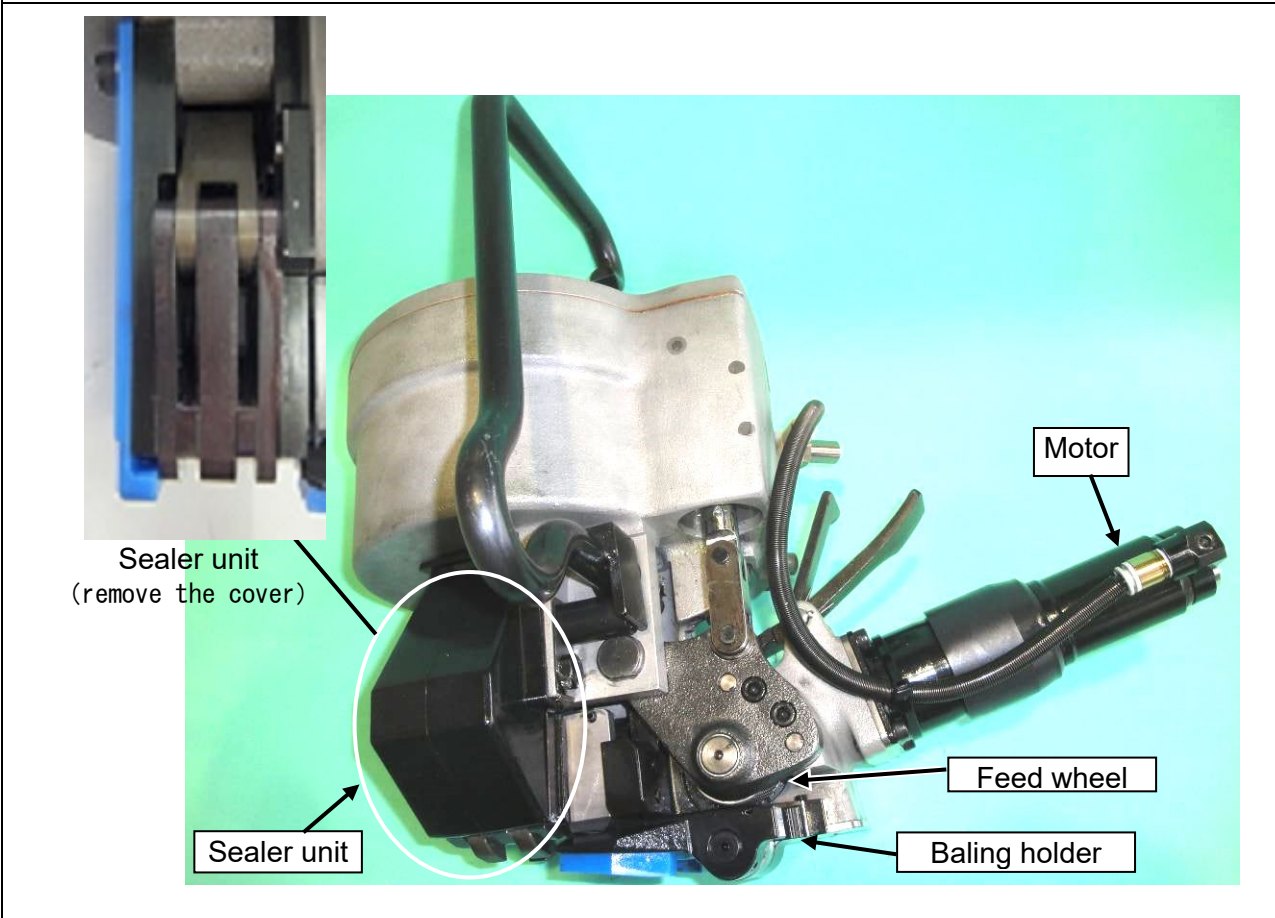
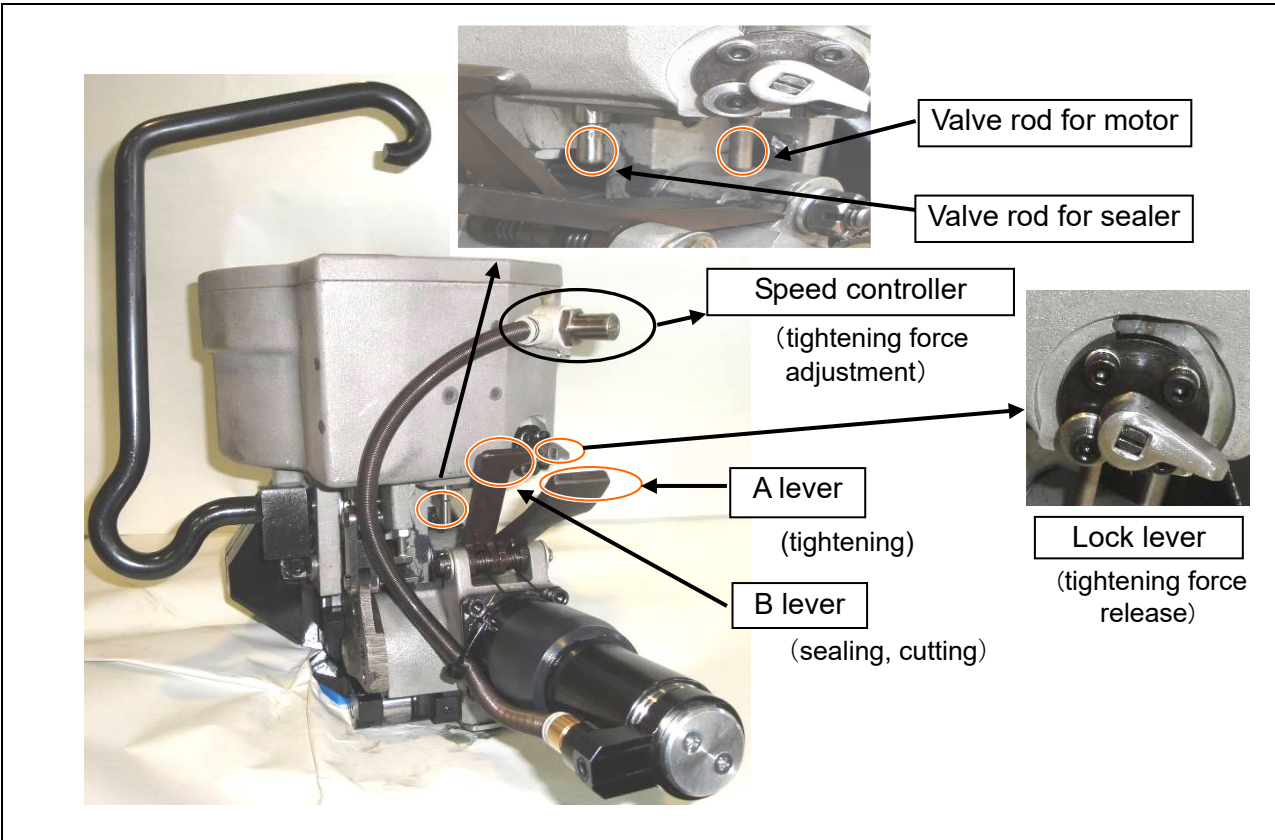

5-2. Operating method

<p>1) How to pass a seal through a strap and bind strap</p>	
	<p>① Pass a strap through in a seal. Then, wind the strap around an object.</p> <div style="border: 2px solid black; padding: 5px; text-align: center;"> <p><b>【⚠ DANGER】</b> Wear protective gloves</p> </div>
	<p>② Pass the end of the strap through in the seal. Then, fold the end of the strap under the seal (folding length is approximately 50mm)</p>
	<p>③ Tighten the strap passed through the seal in the arrow direction to remove excess looseness. At that time, locate the seal at the approximately final position.</p>
<p>2) Strap setting</p>	
	<p>① Gripping the motor at the right hand, please let the top of the strap to stable the tool.</p> <p>② Insert the upper strap between the baling holder and feed wheel from the side. At this time, fully insert the strap until it hits the inner wall of the baling holders.</p> <div style="border: 2px solid black; padding: 5px; text-align: center;"> <p><b>【⚠ CAUTION】</b> Do not touch the tightening part and blade part when setting.</p> </div>

### 3) Tightening



- ① Depress lever A, and valve rod being pushed, air motor begins to rotate, advances the tool in the arrow direction to tighten the strap.
- ② The tool stops with the strap being tightened.  
※If you want to stop rotation of air motor on the way of tightening, turn lock lever clockwise with your fingers, and valve rod for motor returns to the original position.

### 4) Sealing and cutting



- ① Depress lever B and sealing is done by actuating valve rod.
- ② After sealing operation is done, excess strap is cut off.

**【⚠ DANGER】**

After pushing B lever, at starting sealing, Release the finger from A lever and B lever in order not to pinch.

### 5) Removal of tool



After the whole operation is over, all sections return to original state automatically. Therefore, move the tool in the arrow direction to complete the removal.

**【⚠ DANGER】**

There is an exhaust port in the cylinder body. Air comes out at the time of sealing. Do not bring your face close to it.

**【※ Notes】**

If the operating lever is pressed while the band iron and seal are not properly set, a sealing failure may result.

### 5-3. Adjustment

#### Tightening force adjustment by Speed controller

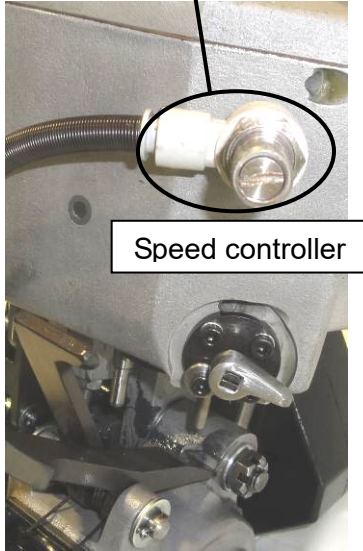
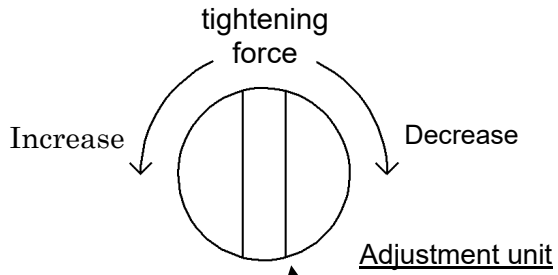

It is possible to adjust tightening force by Speed controller.

In order to adjust tightening force:  
Turn Speed controller as in the left figure by flathead screwdriver.

### 5-4. Operating suggestions

#### 1) Use hook

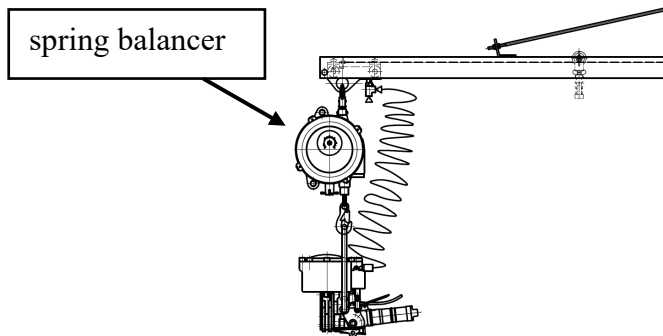

Hang this binding tool from the spring balancer.

## 6. Exploded-view Drawing & Bill of Materials

### 6-1. Exploded-view Drawing : Sealing mechanism

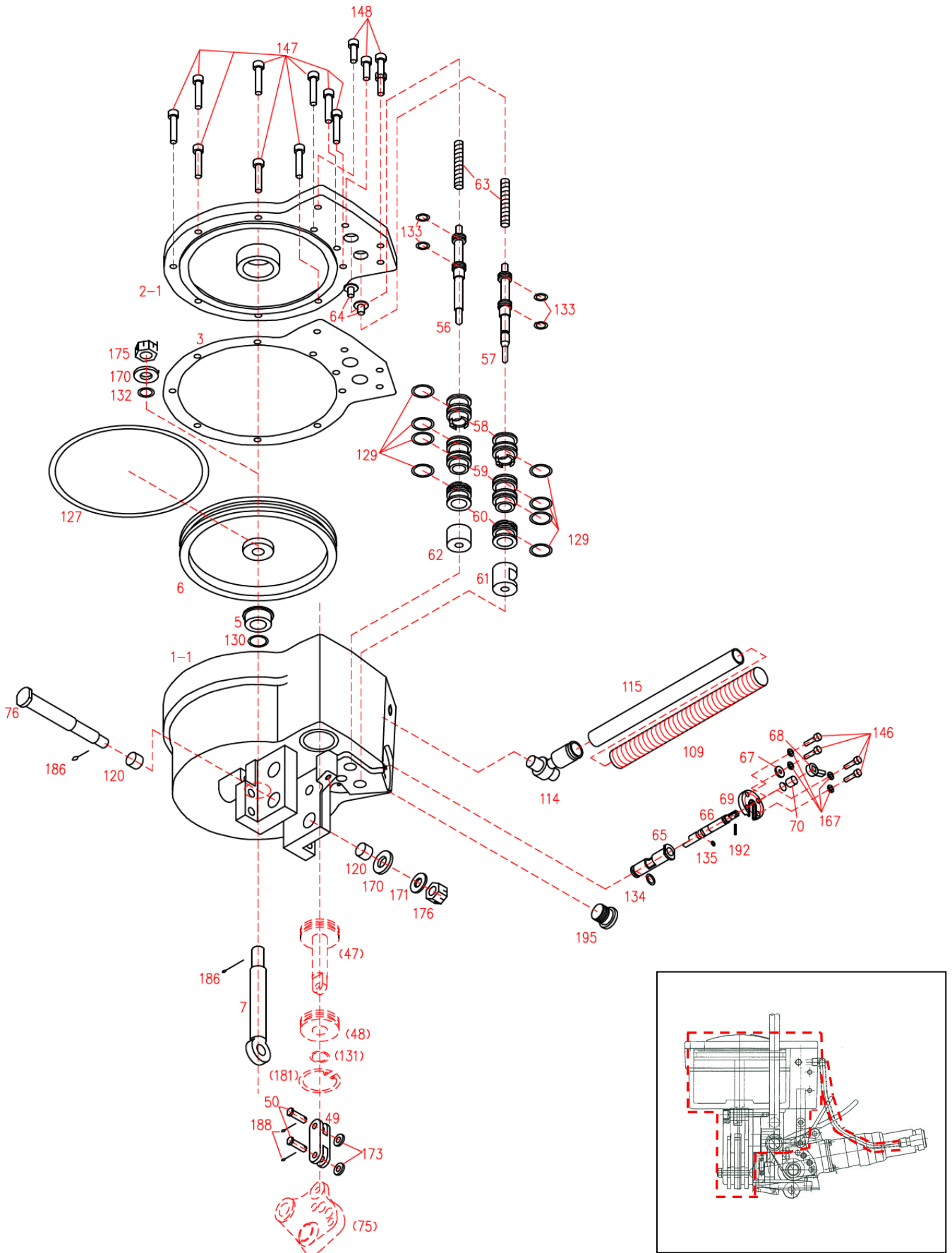

## 6-2. Bill of Materials : Sealing mechanism

(1/2)

KEY No.	Parts Name	(Parts No.)	DWG.No (Model No)	Q'ty			Expendable-parts
				32	25	19	
1-1	Cylinder Body	11817	BK4790-1 BK4791-1	1	1	1	
2-1	Cylinder Cover	1184	BK4792-1	1	1	1	
3	Packing	11851	CK12622-1	1	1	1	○
5	Piston Rod Bush	1008	EK10256-1	1	1	1	
6	Piston	1010	DK10036-1	1	1	1	
7	Piston Rod	1012	EK10257-1	1	1	1	
49	Miniature Cylinder Link	1054	EK10273-1	1	1	1	
50	Miniature Cylinder Link Pin	1055	EK8757-1	2	2	2	
56	Sealer Valve Rod	1187	DK7789-1	1	1	1	○
57	Motor Valve Rod	1189	DK7790-1	1	1	1	○
58	Bush (A)	1191	DK10005-1	2	2	2	
59	Bush (B)	1193	DK10006-1	2	2	2	
60	Bush (C)	1195	DK10007-1	2	2	2	
61	Bush (D)	1197	EK0199-1	1	1	1	
62	Valve Rod Support	1210	EK0206-1	1	1	1	
63	Spring (Sealer)	1198	EK0200-1	2	2	2	○
64	Spring Stopper	1216	EK0472-1	2	2	2	
65	Lock Support	12001	DK2193-1	1	1	1	
66	Lock	12021	DK0467-1	1	1	1	○
67	Spring Support	1218	EK0782-1	1	1	1	
68	Lock Lever	12051	EK19611-1	1	1	1	
69	Lock Guide	1202	EK2562-1	1	1	1	
70	Lock Spring	12081	EK1098-1	1	1	1	○
76	Hanger Pin	1086	EK10279-1	1	1	1	○
109	Spring	1311	DK18080-1	1	1	1	
114	Speed Controller	Purchase	(AS3201F-02-08SD)	1	1	1	○
115	Urethane Tube	Purchase	(φ8×400 L)	1	1	1	○
120	Bush	Purchase	(MLE1410)	2	2	2	
127	O-Ring	Purchase	( P 145)	1	1	1	○
129	O-Ring	Purchase	( P 18)	8	8	8	○
130	O-Ring	Purchase	( P 16)	1	1	1	○
132	O-Ring	Purchase	( P 12)	1	1	1	○
133	O-Ring	Purchase	( P 9)	4	4	4	○
134	O-Ring	Purchase	( P 8)	1	1	1	○
135	O-Ring	Purchase	( S 5)	1	1	1	○



6-3. Exploded-view Drawing : Locking mechanism • Piston • Hook

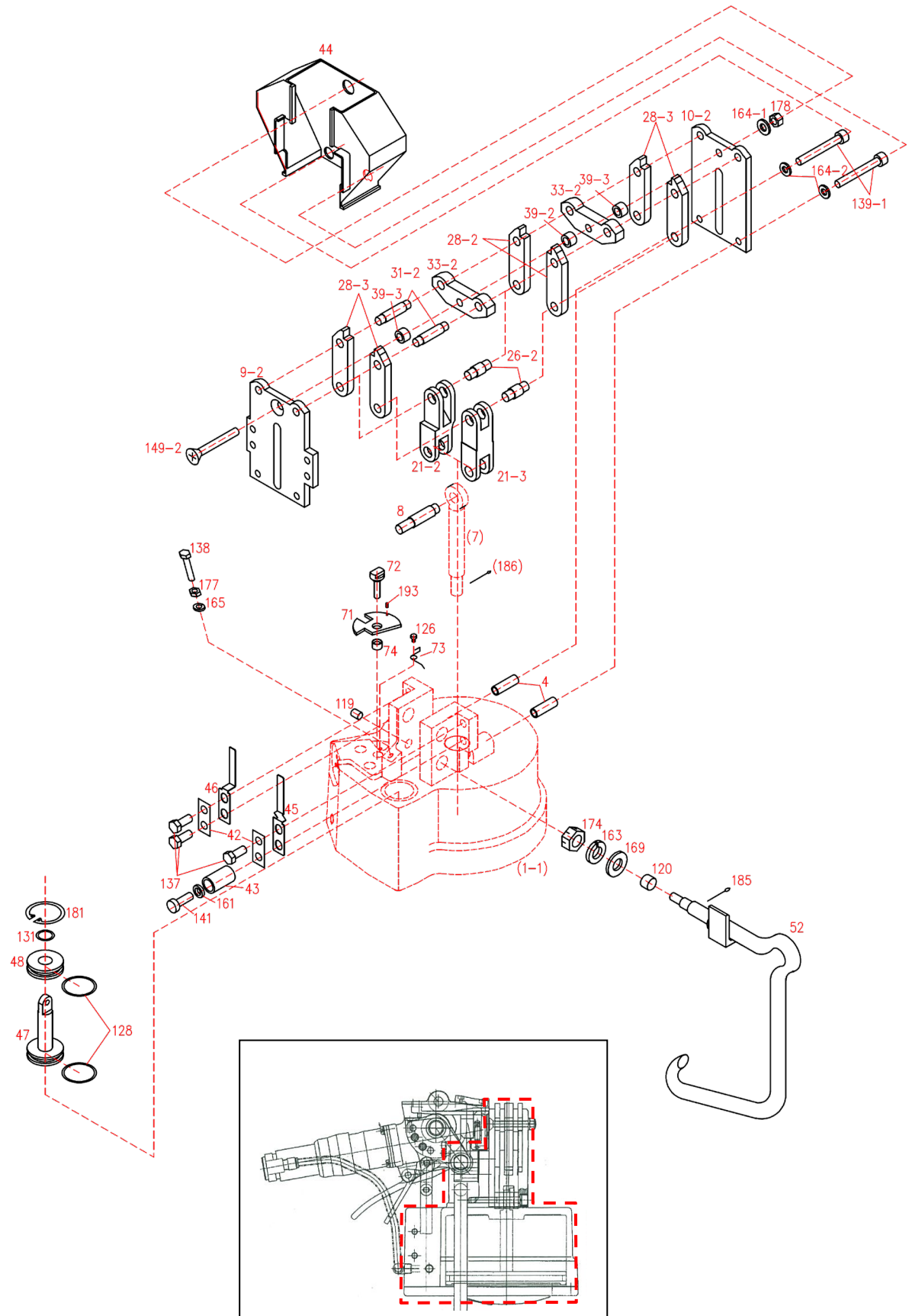

6-4. Bill of Materials : Locking mechanism · Piston · Hook

(1/2)

KEY No.	Parts Name	(Parts No.)	DWG.No (Model No)	Q'ty	Expendable-parts
				32	
4	Steel Bush	1006	EK10255-1	2	
8	Piston Rod Pin	1023	EK10258-1	1	○
9-2	Inside Plate (32D)	1308	DK5424-1	1	○
10-2	Outside Plate (32D)	1309	DK5425-1	1	○
21-2	Link (1) (32D)	1306	DK5426-1	1	
21-3	Link (2) (32D)	1307	DK5427-1	1	
26-2	Link Pin (32D)	1303	EK4913-1	2	○
28-2	Cutter(1) (32D)	1301	DK5428-1	2	○
28-3	Cutter(2) (32D)	1302	DK5429-1	4	○
31-2	Cutter Pin (32D)	1304	EK4912-1	2	○
33-2	Anvil (32D)	1305	EK4911-1	2	○
39-2	Spacer (32D)	13041	EK4914-1	1	
39-3	Spacer (ノ) (32D)	13042	EK4914-2	2	
42	Washer	1220	EK2579-1	2	○
43	Stopper	1175	EK19705-1	1	
44	Link Cover	1030	CK12696-1	1	
45	Cover Holder (1)	1031	EK19919-1	1	
46	Cover Holder (2)	1032	EK19920-1	1	
47	Miniture cylinder Piston	1049	EK10271-1	1	
48	Miniture cylinder Bush	1050	EK10272-1	1	
52-1	Hook (A)	11741	CK12548-1	} 1 selection	
52-2	Hook (E) Option	---	CK13595-1		
52-3	Hook (SC) Option	---	BK5289-1		
52-4	Hook (A)-(Thermal refining) Option	---	CK12966-1		
71	Cam	1211	EK0207-1	1	○
72	Screw For Cam	12121	EK1134-1	1	
73	Cam Spring	1213	EK0209-1	1	○
74	Collar	12141	EK1135-1	1	
119	Bush	Purchase	(MLE0810)	1	
120	Bush	Purchase	(MLE1410)	1	
126	Flat Head Rivet	Purchase	(φ3×5)	1	
128	O-Ring	Purchase	(P32)	2	○
131	O-Ring	Purchase	(P15)	1	○
137	Hexagon Head Bolt(high-tensile)	1224	(M8×20)	3	
138	Hexagon Head Bolt	Purchase	(M6×30SUS)	1	
139-1	Hexagon Socket Head Cap Screw	Purchase	(M8×60)	2	
141	Hexagon Socket Head Cap Screw	Purchase	(M8×45)	1	



6-5. Exploded-view Drawing : Gear Case • Baling Holder

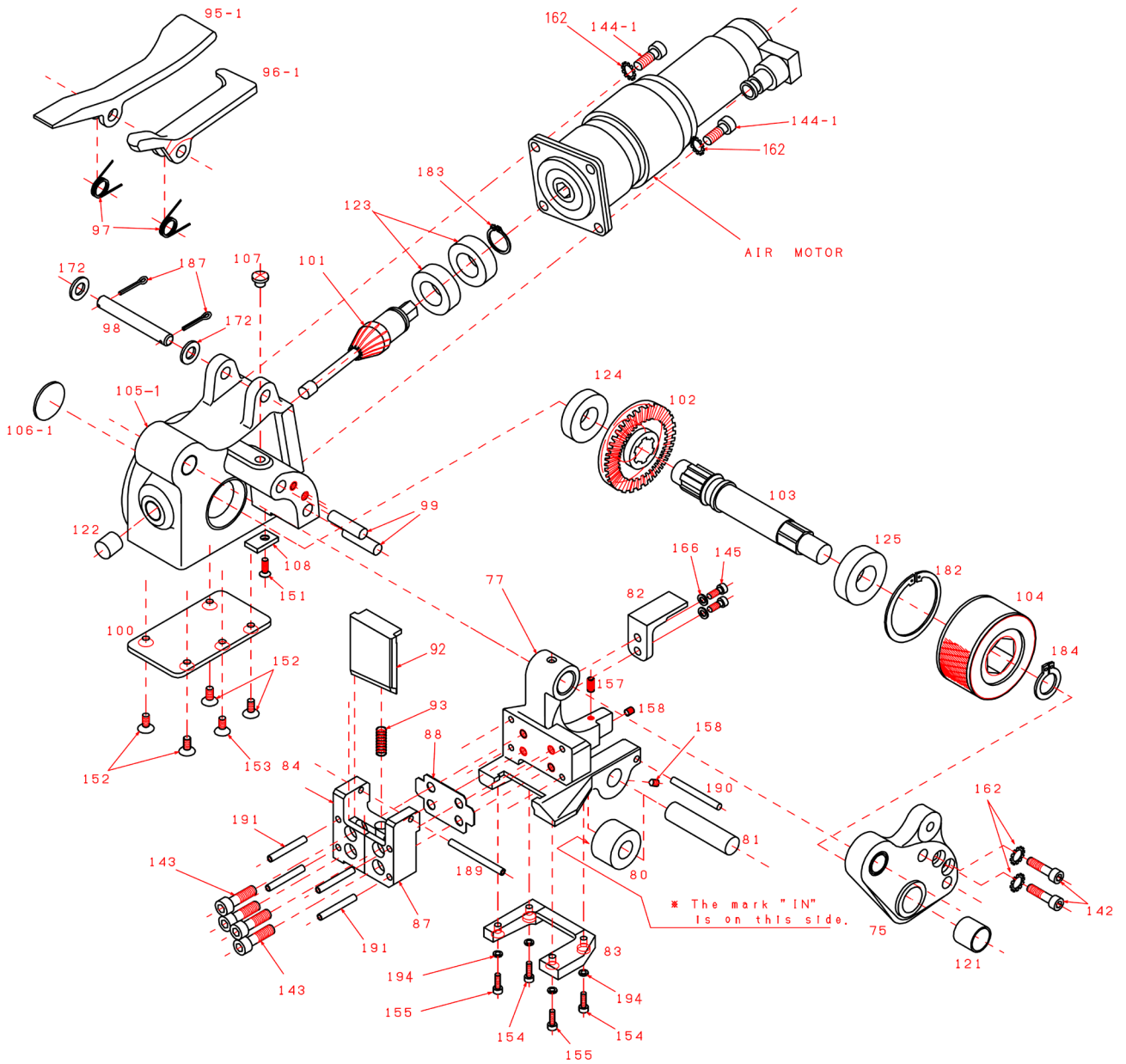

6-6. Bill of Materials : Gear Case ・ Baling Holder

(1/2)

KEY No.	Parts Name	(Parts No.)	DWG.No (Model No)	Q'ty	Expendable-parts
				32	
75	Main Shaft Hanger	1140	DK10040-1	1	
77	Baling Holder (32)	1063	CK6643-1	1	
80	Roller	1066	EK10275-1	1	○
81	Roller Shaft	1067	EK8743-1	1	○
82	Stopper Angle	1068	EK9294-1	1	○
83	Spacer	1310	EK19627-1	1	○
84	Shear Frame (32)	1075	CK6644-1	1	
87	Shear Frame	1074	CK6644-2	1	
88	Shear Frame Shim	1085	EK10277-1	1	
92	Shear Knife (32D)	10811	DK17990-1	1	○
93	Shear Spring	1084	EK10278-1	1	○
95-1	A Lever	11171	DK17902-1	1	
96-1	B Lever	11181	DK17903-1	1	
97	Lever Spring	12052	EK19612-1	2	○
98	Lever Pin	1120	EK8742-1	1	
99	Knock Pin	0017	(MST8-30)	2	
100	Bottom Plate	00212	DK12728-1	1	
101	Hypoid Pinion	0009	DK9117-4	1	○
102	Hypoid Gear	0014	DK9113-4	1	○
103	Main Shaft	1136	DK10004-1	1	
104	Feed Wheel	1138	DK10047-1	1	○
105-1	Gear Case	1122	CK6977-1	1	
106-1	Plug(for Gear case)	1127	EK10284-1	1	
107	Gear Case Point	1124	EK10283-1	1	
108	Stopper Plate	0012	EK8934-1	1	
121	Bush	Purchase	(MLE1515)	1	○
122	Needle Bearing	Purchase	(BK0810CT)	1	○
123	Deep Groove Ball Bearing	Purchase	(#6003ZZ)	2	○
124	Deep Groove Ball Bearing	Purchase	(#16002)	1	○
125	Deep Groove Ball Bearing	Purchase	(#6003ZZ)	1	○
142	Hexagon Socket Head Cap Screw	Purchase	(M6×25)	2	
143	Hexagon Socket Head Cap Screw	Purchase	(M6×20)	4	
144-1	Hexagon Socket Head Cap Screw	Purchase	(M6×18)	4	
145	Hexagon Socket Head Cap Screw	Purchase	(M5×15)	2	○
151	Countersunk Head Screw	Purchase	(M5×16)	1	
152	Countersunk Head Screw	Purchase	(M4×15)	4	○
153	Countersunk Head Screw	Purchase	(M4×12)	1	○



6-7. Exploded-view Drawing : Air Motor

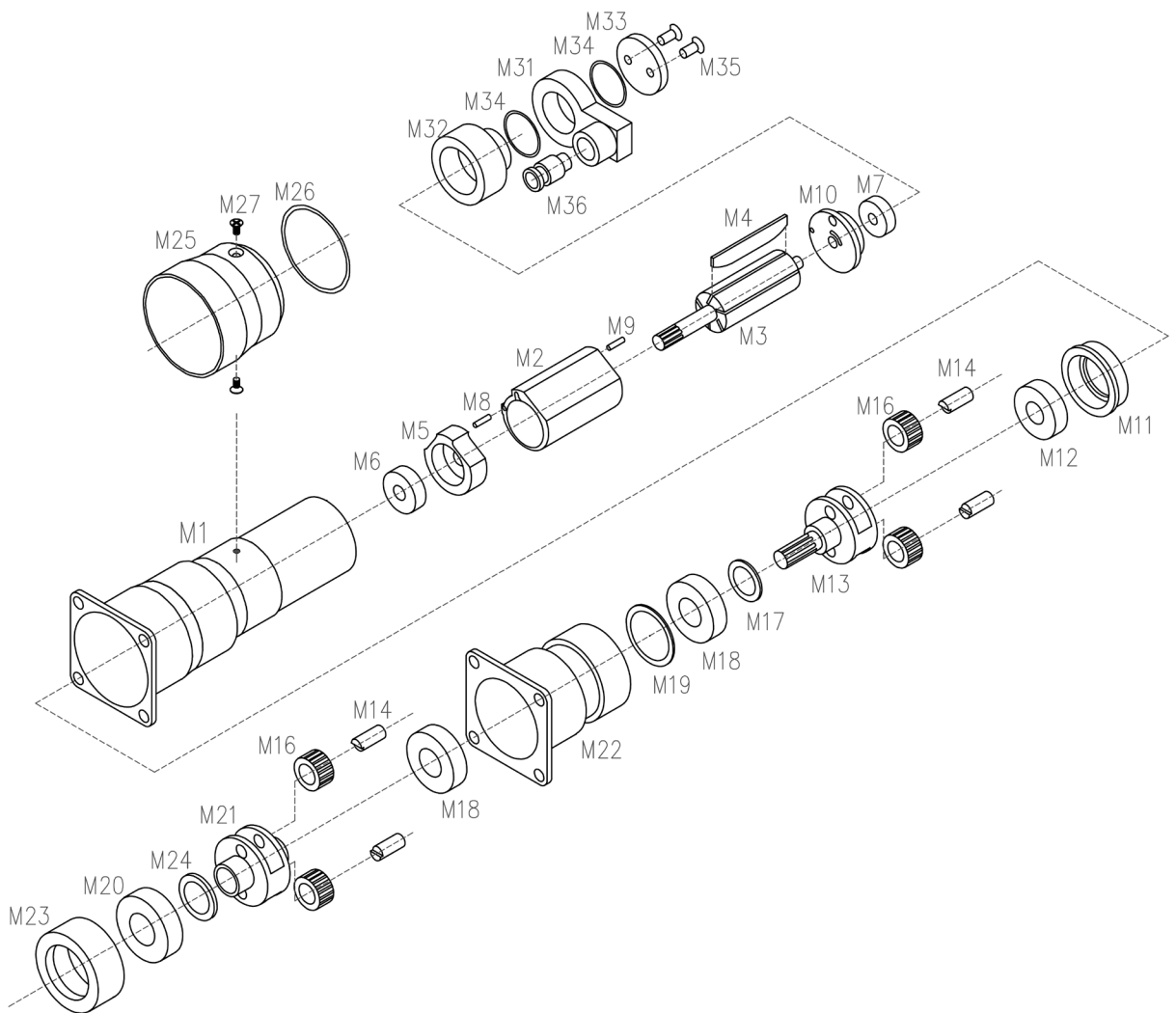

6-8. Bill of Materials : Air Motor

KEY No.	Parts Name	(Parts No.)	DWG.No (Model No)	Q'ty	Expendable-parts
				32	
M1	Motor Case	01012	DK18412-1	1	
M2	Cylinder	01181	CK12522-1	1	○
M3	Rotor	01211	DK18012-1	1	○
M4-1	Vane	01222	EK19753-1	5	○
M5	Front Cylinder Cover	01171	DK18057-1	1	○
M6	Deep Groove Ball Bearing	Purchase	(#608ZZ)	1	○
M7	Deep Groove Ball Bearing	Purchase	(#626ZZ)	1	○
M8	Needle Pin(Heat treatment)	Purchase	(φ2×7.8)	1	○
M9	Needle Pin(Heat treatment)	Purchase	(φ2×6.8)	1	○
M10	Rear Cylinder Cover	01241	DK18058-1	1	○
M11	Bearing Box For 1st Idle Frame	0115	DK12135-1	1	
M12	Deep Groove Ball Bearing	Purchase	(#6001ZZ)	1	○
M13	1st Idle Frame	0110	DK12136-1	1	
M14	Idle Gear Shaft	0111	EK13332-1	4	○
M16	Idle Gear(With Needle bearing)	0113	EK13333-1	4	○
M17	1st Idle Frame Washer	0109	EK8744-1	1	
M18	Deep Groove Ball Bearing	Purchase	(#6002ZZ)	2	○
M19	Bearing Ring For Internal Gear	0108	EK13628-1	1	
M20	Deep Groove Ball Bearing	Purchase	(#6003ZZ)	1	○
M21	2nd Idle Frame	01061	DK19086-1	1	
M22	Internal Gear	0102	DK0270-1	1	
M23	Spacer	0103	EK13629-1	1	
M24	2nd Idle Frame Washer	0105	EK8745-1	1	
M25	Exhaust Cover	01301	EK20213-1	1	
M26	O-ring	Purchase	(S42)	1	○
M27	Countersunk Head Screw	Purchase	(M3×8)	2	○
M31	Sup Ring	1312	DK84028-1	1	
M32	Cylinder Spacer	1313	DK18048-1	1	
M33	Ring Spacer	1915	E64458-1	1	
M34	O-ring	Purchase	(S22)	2	○
M35	Countersunk Head Screw	Purchase	(M4×12)	2	○
M36	Hexagon Socket Head Harf Union	Purchase	(KQ2S08-02AS)	1	○

6-9. Exploded-view Drawing :Option

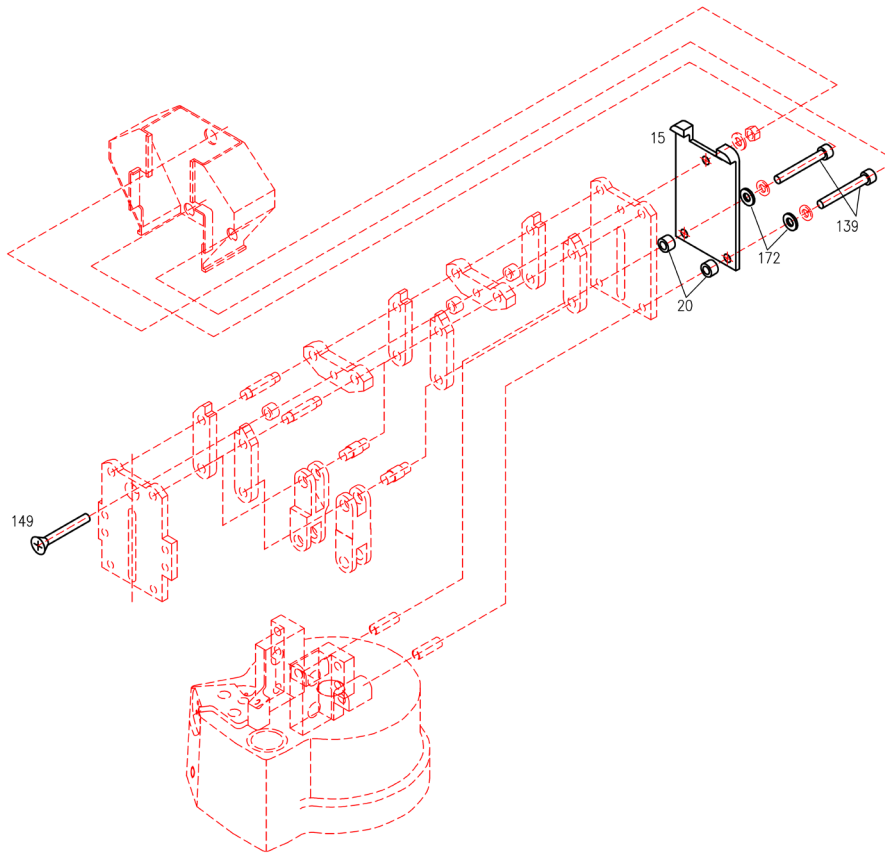

6-10. Bill of Materials : Option

KEY No.	Parts Name	(Parts No.)	DWG.No (Model No)	Q'ty	Expend able-parts
				32	
15-2	Protector	1228	E64656-1	1	
20	Spacer	1229	EK20142-1	2	
139-3	Hexagon Socket Head Cap Screw (For Protector)	Purchase	(M8×70)	2	
149-4	Hexagon Socket Countersunk Head Screw(For Protector)	Purchase	(M8×65)	1	
172	Plain Washer(For Protector)	Purchase	(M8)	3	

## 7. Troubleshooting

Trouble condition	Cause	Actions to take
1. Malfunction	1. Low air pressure	1. Check to see whether the pressure gauge attached to the pressure reducing valve indicates the correct pressure. If the pressure is too low, make adjustment to the correct pressure. If the pressure is insufficient, the tightener unit by the miniature piston may not be lifted up (poor strap insertion state).
	2. Insufficient air pressure ( Hose size : 3/8B×5m Flow : Max1.1Nm <sup>3</sup> /min)	1. Check to see if the size of the hose supplying air to the tool is correct. If the size is not correct, replace the hose.
		2. Remove the main body and blow off compressed air through the air hose only, and check to see if the flow rate to the hose is correct. At this time hold the end of the hose firmly. Replace the rubber hose if the air supply amount is small due to the internal diameter having become small due to oil etc.
		3. Check each operation to see if the valve can be switched by lever operation.
		4. Check to see if the speed controller is adjusted appropriately.
		5. Check each part for air leakage and take action. If air leaks, it is considered that the packing is broken or tightening is poor, then repair is required.
	3. Insufficient lubricant	1. If lubricator drop of the air set (F.R.L combination) is insufficiently adjusted, correct it. And inject some drops of turbine oil from the air supply port on the main body.

Trouble condition	Cause	Actions to take
1. Malfunction	4. Looseness of joint screw	1. Looseness of the following screws or bolts results in a start failure, therefore, check and tighten them. <ul style="list-style-type: none"> <li>●Bolts for side plates and links, etc., on the sealer part</li> <li>●Mounting bolts for the cylinder and cover.</li> <li>●Motor mounting bolts for the tightener part, mounting bolts for the main shaft hanger unit and stopper bolts.</li> </ul>
	5. If there is no improvement even by the above operation	1. Internal abnormality is considered. Therefore, contact our distributor or our company. <Example> ~Cylinder-related~ <ul style="list-style-type: none"> <li>●Malfunction due to rust (caused by inflow of moisture etc.), foreign substance. etc., in cylinder.</li> <li>●Breakage or wear of piston rod pin, nut, O-ring and piston, etc.</li> </ul> ~Valve unit-related~ <ul style="list-style-type: none"> <li>●Air leakage or malfunction due to foreign substance etc., on spool valve rod</li> <li>●Breakage or wear of lantern ring, spring for spool valve rod, O-ring, etc.</li> </ul> ~Motor-related~ <ul style="list-style-type: none"> <li>●Rotation failure to rust (caused by inflow of moisture etc.)or foreign substance etc ., in air motor.</li> <li>●Breakage, wear and adherence of internal parts such as Rotor, Gear, Bearing etc.</li> <li>●Misalignment between Cylinder and Nock pin for cylinder cover.</li> </ul> ~Gear case-related~ <ul style="list-style-type: none"> <li>●Breakage or wear of gear and bearing, etc.</li> </ul>

Trouble condition	Cause	Actions to take
2. Strap insertion failure	1. Baling holder opening shortage	1. Check to see if the stopper bolt is properly positioned. Make adjustments in case of shortage.
		2. Check to see if the miniature piston is sufficiently lifted up. (Check with the stopper.)
3. Insufficient tightening force	1. When air supply pressure and supply amount are insufficient	1. For inspection of air amount, check to see if the difference in pressure between when the tightener is stopped and when idling has not significantly decreased. If it has decreased, the flow rate is insufficient.
		2. If the distance from the air set(F.R.L combination) to Tightener is too long and they are connected with an air hose for piping, the air pressure is reduced. Therefore the distance should be 5 m or less.
		3. Check to see if the tightening speed is low by adjusting the speed controller.
		4. Check to see that there are no air leaks etc., from the main body. If there are air leaks etc., tighten screw etc. additionally. Contact our distributor or our company because disassembly will be required in case of defective internal parts.
	2. Malfunction by feed wheel	1. Inspect the feed wheel for clogging. Remove the feed wheel from the tightener. Then clean the feed wheel by contacting a wire brush. Periodic cleaning of the feed wheel is effective. If it is worn or damaged, etc., replace with a new one.

Trouble condition	Cause	Actions to take
3. Insufficient tightening force	2. Malfunction by feed wheel	2. Inspect if the clearance between the roller and the feed wheel open correctly. Adjust the clearance by the adjustment screw on the rear of the bailing holder.
		3. Inspect the blade edge of the feed wheel. Replace any worn or damaged blades with new ones.
		4. Check carefully if the bailing holder is not significantly deformed or cracked.
	3. Air motor does not work	1. Check to see if there is abnormal noise or low rotating noise of air motor. dust may be contained in the air motor. Therefore, disassembly or maintenance is immediately required.
		2. If exhaust noise becomes large at the completion of tightening (motor load stop), the vanes may be excessively worn at the sliding surface. Therefore, the vanes etc. must be replaced.
	4. Malfunction by miniature piston	1. Press the valve lever (lever A) for a motor to check to see if the tightener part (motor) descends and there is no air leakage.
		2. The locking mechanism may be defective. Check the movement of the motor valve rod for release of tightening operation at the time of the sealer.
		3. Check to see that there are no air leaks from the valve rod and hose, etc., at the time of lever operation. If air leaks, it is necessary to replace O-ring etc.

Trouble condition	Cause	Actions to take
4. Strap cutting failure	1. Air pressure decreases.	1. Reduction in air pressure causes a cutting failure of the band. Check that the air pressure has been adjusted to a predetermined pressure.
		2. Shearing force is supplied from sealing cylinder. Refer to sealing operation.
	2. Blade edge of shear knife is worn or damaged.	1. Inspect the blade edge of the shear knife. If it is worn or damaged, replace it with new one.
5. Poor sealing including poor strength of sealed part	1. Low air pressure	1. Low air pressure will cause a cutting failure of the straps. Check to see if the air pressure is as specified.
	2. Wear or chip of cutter	1. If the depth and height of the notch are insufficient, resulting in poor sealing, replace it. After replacement, confirm that the depth and height of the notch are normal by testing. It is recommended to keep new-product notch samples for notch confirmation use after maintenance.
	3. Wear spacer	
	4. Wear or break of cutter pin, link pin or piston rod pin	
	5. Wear or break of side plate	
	6. Wrong shape of seal	1. Conduct seal sampling inspections to confirm conformity with the shape dimensions
	7. Nut of piston rod becoming loose	1. Internal abnormality is considered. Contact our distributor or our company.
	8. Wear or break O-ring of piston	
	9. Wear or break O-ring for the sealer valve	
	10. Wear or break piston and cylinder	

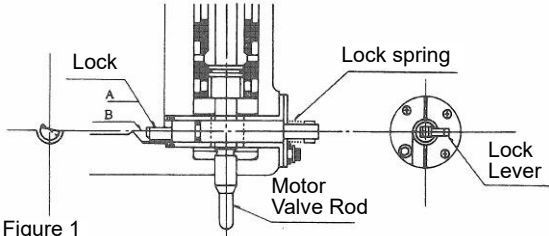
Trouble condition	Cause	Actions to take
5. Poor sealing including poor strength of sealed part	11. A foreign body being clogged between piston and cylinder	1. Internal abnormality is considered. Contact our distributor or our company.
	12. Automatic machine does not work	1. Did the sealer mechanism return to the start point? It returns to the start point when the lock lever attached at the end of the lock (device which operates when sealing completely ends) is depressed.   <p>Figure 1</p>
6. Other	1. Abnormal noise or heat is generated	1. If any abnormal noise or heat is generated during operation, immediately stop operation and inspect each part.

## 8. Air Logic and Diagram

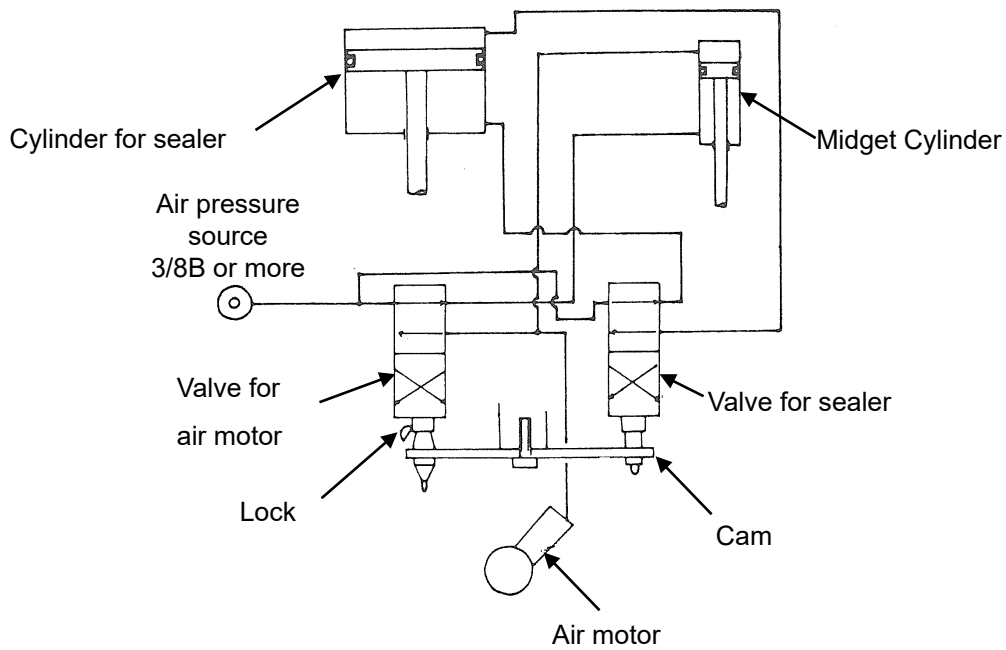

### Operational description

1. When air is connected to the main body, the feed wheel and air motor ascend.
2. When pressing the valve lever (A lever) for the motor of the tool, the valve for the air motor is switched, the air motor rotates to tighten the strap.
3. When pressing the valve lever (B lever) for the cylinder of the tool, the valve for the sealer is switched, the cylinder for the sealer descends to seal and shear the seal.
4. After the whole operation is over, all sections return to original state automatically by the action of lock.

# KohanKogyo

KOHAN KOGYO CO., LTD.

## ■帯鋼機器営業部門

東京営業部 〒141-0022 東京都品川区東五反田 18 番 1 号 (大崎フォレストビルディング 19F)  
Tel. 03-4531-6891、FAX. 03-3280-8162

大阪営業部 〒541-0041 大阪府中央区北浜 4 丁目 7 番 19 号 (住友ビル 3 号館 4F)  
Tel. 06-6223-4680、FAX. 06-6223-4681

下松営業部 〒744-0011 山口県下松市西豊井 1394 番地  
Tel. 0833-43-1824、FAX. 0833-44-0964

Tokyo Sales Department Osaki Forest Building, 2-18-1 Higashi-Gotanda Shinagawa-Ku,  
Tokyo, 141-0022, Japan, Tel. +81-3-4531-6891

Osaka Sales Department Sumitomo Building 3Go-Kan, 4-7-19 Kitahama, Chuo-Ku,  
Osaka, 541-0041, Japan, Tel. +81-6-6223-4680

Kudamatsu Sales Department 1394 Nishitoyoi, Kudamatsu, Yamaguchi,  
744-0002, Japan, Tel. +81-833-43-1824

■機 器 工 場 〒744-0011 山口県下松市西豊井 1394 番地 Tel.0833-43-2640  
Machinery Works 1394 Nishitoyoi, Kudamatsu, Yamaguchi 744-0011, Japan  
Tel. +81-833-43-2640

## ■海外営業所 / 現地法人

### 中 国 / China Branch

SHANGHAI TOYO KOHAN TRADING CO., LTD. "Kohan Kogyo" Division  
Room 2701, Shenggao International Building, No137, XianXia Road Shanghai 200051, China  
Tel. +86-21-6259-1708, Fax. +86-21-6270-3308

### 台 湾 / Taiwan Branch

KOHAN KOGYO CO., LTD. TAIWAN BRANCH (JAPAN)  
No. 26, Ln. 76, Shepi Rd., Fengyuan Dist., Taichung City 420077, Taiwan (R.O.C.)  
Tel. +886-4-2259-2850, Fax. +886-4-2259-2851

### 韓 国 / Korea Branch

KOHAN KOGYO KOREA CO., LTD  
No.115・215, 132-Dong, Busan T-PLEX ,41,Yutongdanji-1Ro(Daejeo-2Dong), Gangseo -Gu, Busan,  
46721, Korea  
Tel.+82-51-710-6342 Fax. +82-70-8282-0526