

IMPORTANT

On beginning to use MV type strapping tool

Thank you for purchasing our product.

On beginning to use this tool, It is necessary to adjust mentioning below.

<Request shim adjustment for point part>

■ **Delivery time**

There are 3 pieces of shim.
Adjust the number of shim to strap thickness.

■ **The method of adjustment**

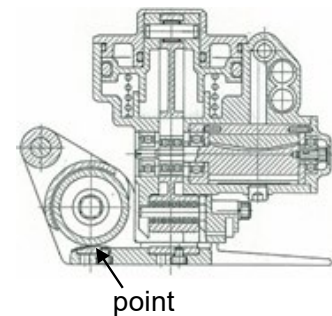

① Remove a hexagon socket head screw with a 3mm hexagon wrench.

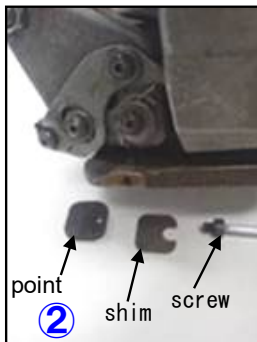

② Remove a point and shim.
● There are 3 pieces of shim
● Adjust the number of shim to strap thickness
● Example : no shim at strap thickness 1mm
a piece of shim at strap thickness 0.8mm



③ Fix a point and shim with screw.

Pneumatic Vibration Welding Type Plastic Strap Binding Tool

MV

INSTRUCTION MANUAL

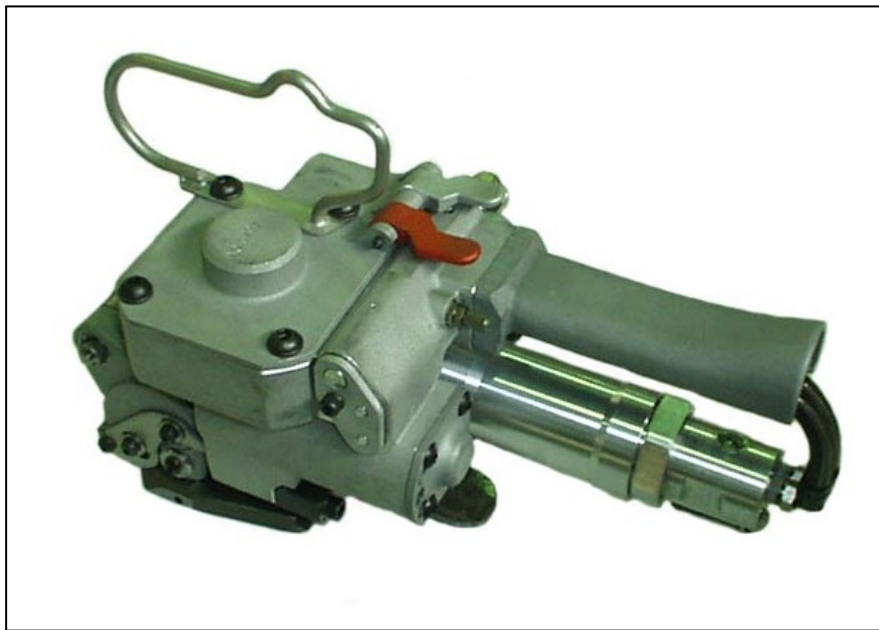

KohanKogyo
KOHAN KOGYO CO., LTD.

Rev.4_B

— Contents —

Introduction	-----
1. Safe Use Method	-----
2. Principle of Welding	-----
3. Specifications	-----
4. Air Source	-----
5. Name of Each Part	-----
6. Operating Method	-----
7. Cautions for Use	-----
8. Attached Parts	-----
9. Check Points After Assembling	-----
10. Trouble Shooting	-----
11. Pneumatic Diagram	-----

Introduction

This is a manual strapping tool of a pneumatic vibration welding type used for a 25 mm wide ester strap.

(Some can be used for a 16 mm or 19 mm wide strap by exchanging parts.)

Close attention has been paid to the design and production of this tool.

To use this product properly, some amount of practice as well as cautions in use are necessary. To use the product without worry, it is important to observe the correct use method specified in this instruction manual.

When banding packaged objects with this tool, a 70 mm long base plate remains under the banded strap, therefore, some amount of loosening of the strap may be generated after pulling out the base plate after banding.

To avoid this loosening, it is vital that there is a level surface of 150 mm or more on the banding surface. Therefore, basically this tool is not suitable for round shaped packaged objects such as coils. This is suitable for banding work of box shaped objects.

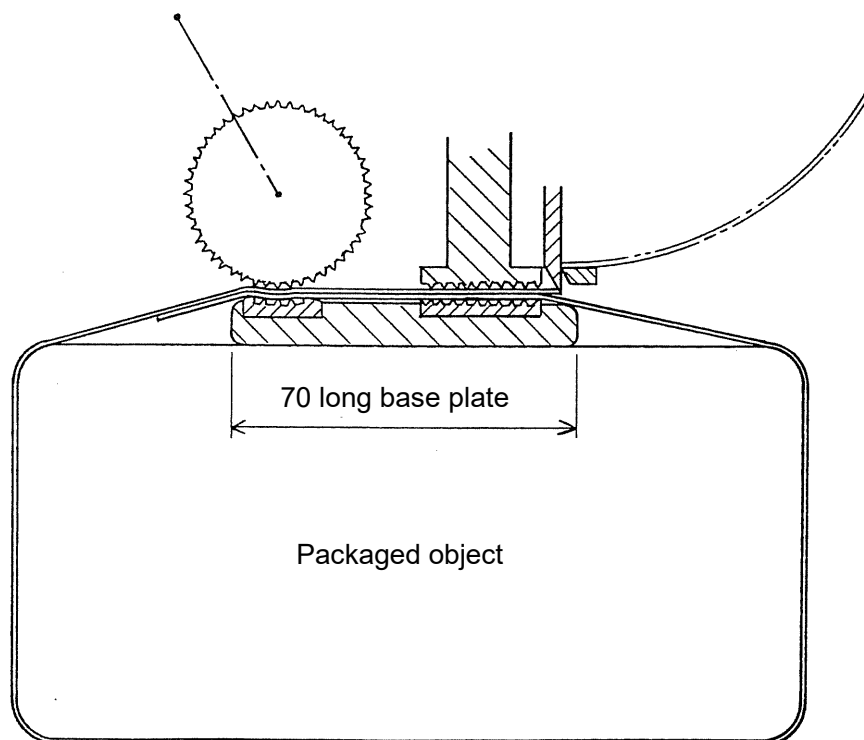

1. Safe Use Method

1-1. General cautions

- (1) Pay attention to safety when using this tool.
Sufficiently understand the safe use method, and use this tool correctly.
- (2) Before action, inspection, care, etc., of this tool, read this instruction manual and understand the correct use method.
- (3) Do not remove the safety device such as the safety cover attached to the tool.
- (4) Do not remove, make illegible or difficult to see the display or the label pasted on the tool.
- (5) Should you have any comments or questions regarding safe use of our tool, please contact our company.

1-2. Application

This tool is designed for the purpose to band around a banded object using a 25 mm(19mm,16 mm) wide PP strap, ester strap for packaging.

Do not hold the banded strap as a handle when transporting, or do not hoist a package with the banded strap as a hanging tool. It may result in a disaster or damage.

1-3. Work clothes

When using this tool, wear protective equipment such as “protective glasses,” “protective mask,” “earplugs,” “leather gloves,” “safety shoes,” and “helmet.”

Also wear a long-sleeved work shirt, buttoning the cuffs, etc. Pay careful attention so as not to get neckties, accessories or hair caught by the tool.

(1) Protective glasses

In the case of cutting a strongly banded strap with scissors, a strap may snap back and damage an eye of a worker resulting in loss of sight. Therefore, always wear protective glasses.

And also when cleaning the tool, the attached dust, etc., may get in eyes by air blowing, etc., so always wear protective glasses.

(2) Protective mask and ventilation

This tool is for vibration type banding, therefore strap dusts may be generated, so always wear a protective mask while using this tool.

Also the exhaust air from the tool is dirty with oil, etc., so provide sufficient ventilation where the tool is handled.

(3) Earplugs

If ears are exposed to the operating noise and the exhaust noise from the tool, it may cause a hearing disorder. To protect ears, always wear earplugs while using the tool.

1-4. Cautions

(1) Vibration

Depending on the vibration level and the total hours of use, this may place the worker in a danger situation.

If a worker is exposed to strong vibration, it may cause physical disorder of the hands and the arms.

Limit the working hours for a worker to within 30 minutes, and take short breaks appropriately.

(2) Rotation

If the tight wheel is touched by a finger tip, or if a finger tip is thrust into while the tight wheel to tighten the strap is rotating, a glove or the like may get caught and it may result in an injury, so absolutely never touch it.

1-5. Inspection and repair

(1) In the case of inspection and repair, stop the supplied air and remove the tool from the air source beforehand.

(2) Inspect the tool before starting work every day, and check that there is no loosening of bolts or damage and then start to use. If there is clogging or dust attachment, etc., of the tight wheel, clean it using a wire brush or air blowing, etc.

(3) As for a tool attached by a suspension (hanging tool), inspect for any loosening of the attached part before work.

(4) If there are worn out or damaged parts, stop using the tool, and inspect and repair it.

1-6. Discarding the tool

“Steel,” “aluminum alloy,” “copper alloy,” “rubber, plastic,” etc., are used in this tool. In the case of discarding it, pay attention so that it does not contaminate and harm the environment and people.

2. Principle of Welding

The principle of welding of this tool is to utilize the frictional heat generated by strongly rubbing objects.

This is a method called Vibration welding, in which the upper side strap is reciprocated at high speed in the width direction while strongly pressing the overlapped two sheets of the upper strap and lower strap to generate frictional heat on the contact surfaces of the strap and to allow the strap surfaces to melt, and then these surfaces are pressurized and cooled down for fixing and joining.

- 2-1. The pressing down force generated to the piston of the air cylinder by pneumatic pressure presses down the vibrator by way of the pressurizing pin on the top end of the vibrator, and pressurizes the overlapping strap strongly.
- 2-2. The top end of the vibrator is supported by the pressuring pin, and the ball bearing in the oval hole of the vibrator center part is reciprocated at high speed to the right and left by the rotor (eccentric shaft) of the air motor rotating at high speed, and a pendulum motion is generated to the vibrator.
- 2-3. The overlapping lower strap is fixed with the serration of the bottom die, and only the top side strap makes a reciprocating motion (vibration) in the width direction, so the contacting two straps generate frictional heat and the strap surfaces melt down.
- 2-4. The two sheets of the overlapping strap with melted contact surfaces are kept pressurized for a few seconds until the tightener is raised, and the melted part is cooled and fixed realizing a strong bonding.

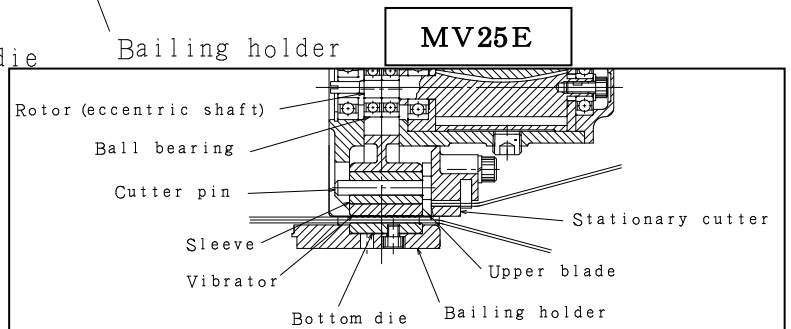
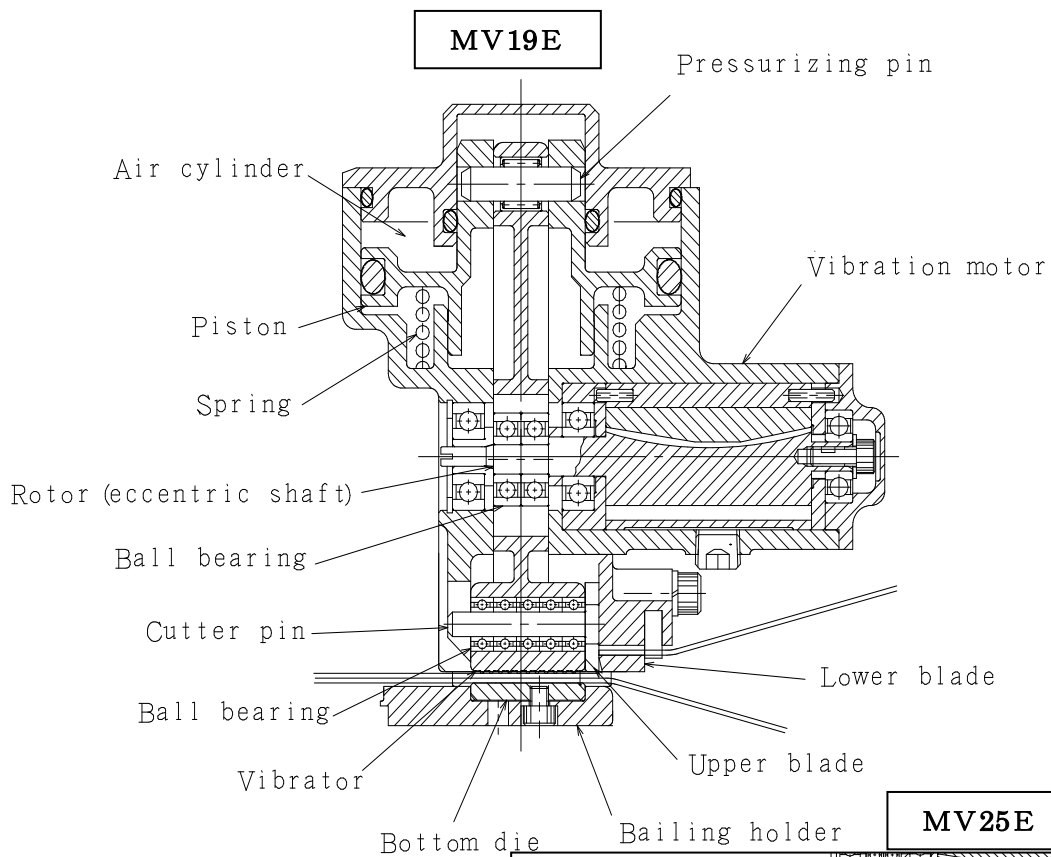
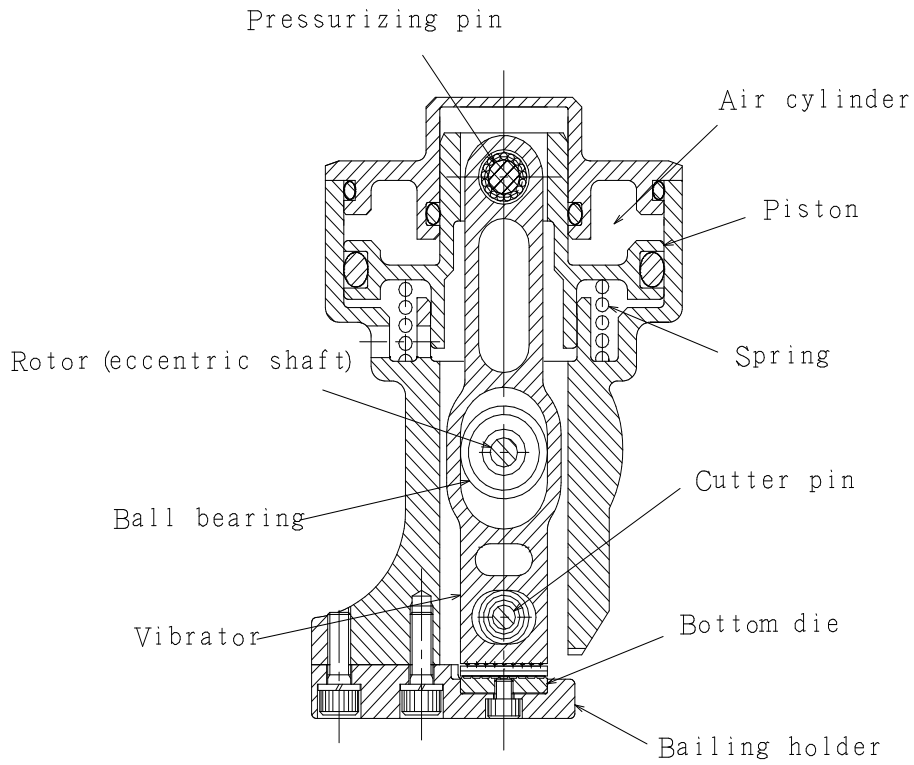

3. Specifications

3-1. Strap to use

The vibration welding method can be applied to all thermoplastic resin straps such as PP straps, ester straps, nylon straps, etc..

3-2. Tool specification

Model	Air tool MV-19E	Air tool MV-25E
Dimensions	Length 275mm × Width 115mm × Height 130mm	Length 275mm × Width 115mm × Height 130mm
Weight	3.8kg	4.2 kg
Welding method	Vibration welding	Vibration welding
Pressurizing method	Air cylinder: $\phi 70 \times 7$ mm ST	Air cylinder: $\phi 70 \times 7$ mm ST
Vibration method	Air motor : Model MPL-45	Air motor : Model MPL-45
Tightening method	Air motor : Model H or M	Air motor : Model H or M
Tightening force	H (high tension type) : 0 to 2,740 N M (middle tension type): 0 to 1,760 N	H (high tension type) : 0 to 2,740 N M (middle tension type): 0 to 1,760 N
Power source (air)	Compressed air Pressure : 0.6 MPa Instant maximum flow rate : 0.7 Nm ³ /min Connection bore diameter: 1/4B (8A) or more	Compressed air Pressure : 0.6 MPa Instant maximum flow rate : 0.7 Nm ³ /min Connection bore diameter: 1/4B (8A) or more

- (1) This can be used for 19E : 19mm or 16mm / 25E : 25mm or 19mm straps by exchanging the side guide.
- (2) Vibration and tightening can be operated separately, so tension adjustment from no tension to maximum tension is possible.
- (3) Tightening force should be used within the elastic range of the strap.

4. Air Source

4-1. About air source

As an air source of this tool, the following is necessary.

- Pipe diameter : 3/8B(10A) or more
- Air flow rate : 1Nm³/min or more
- Pressure (source pressure) : 0.6MPa

(The minimum pressure while this tool is in operation: 0.4 MPa or more)

4-2. Air hose to use

(1) It is recommended to use the following air hose for this tool.

Air hose : 3/8B(10A) x 5m

Hose metal fitting : 3/8B(10A)

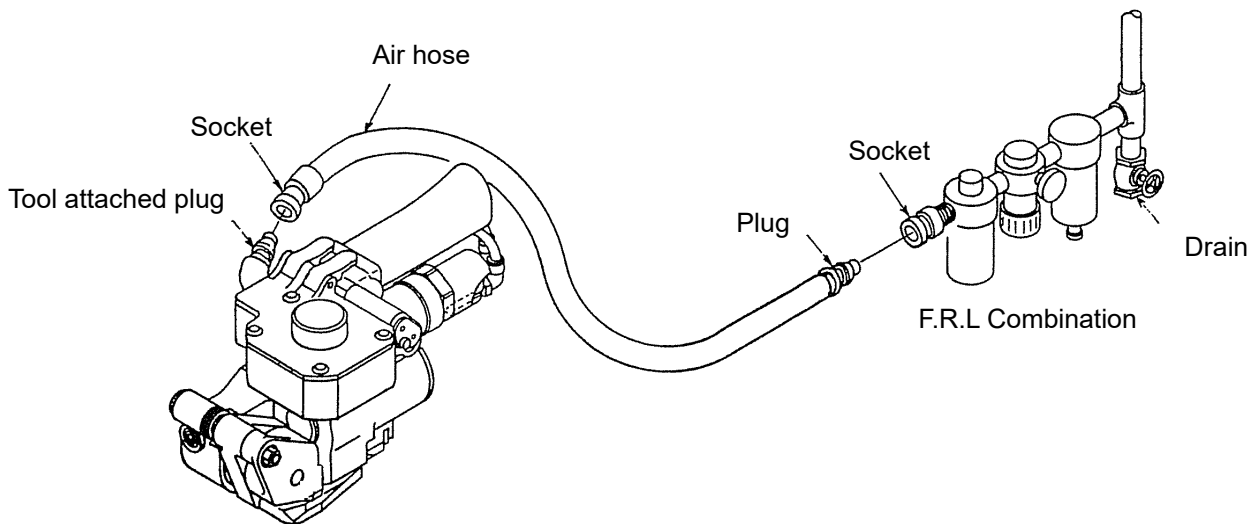

(2) To use a hose other than the above mentioned hose, use a hose with an inside diameter of 9.5 mm or more and a length of 5 m or less. If a hose smaller than the specified size is used, it will result in a sudden pressure drop during action, therefore, pay special attention.

4-3. Cautions for piping

- (1) Attach the F.R.L. Combination (filter, regulator, lubricator) of 3/8B or more to the air source.
- (2) To avoid a pressure drop during operation, all the piping parts of 3/8B or more must be used.
- (3) An air motor is used for this tool, so remove the drain inside the pipe and pay attention that the rust inside the pipe or remnants of the seal tape, etc., do not get in.
- (4) As for the air motor, the rotor rotates at high speed, therefore, if the lubrication oil in the air is insufficient, the rotation speed may lower abnormally, or start-up may be impossible. Always check the level of the lubrication oil (turbine oil 1 type 32) of the lubricator, and adjust the dropping amount of the lubrication, and adjust the oil drop amount so that 20 to 30 drops drip per minute.

5. Name of Each Part

5-1. Appearance names

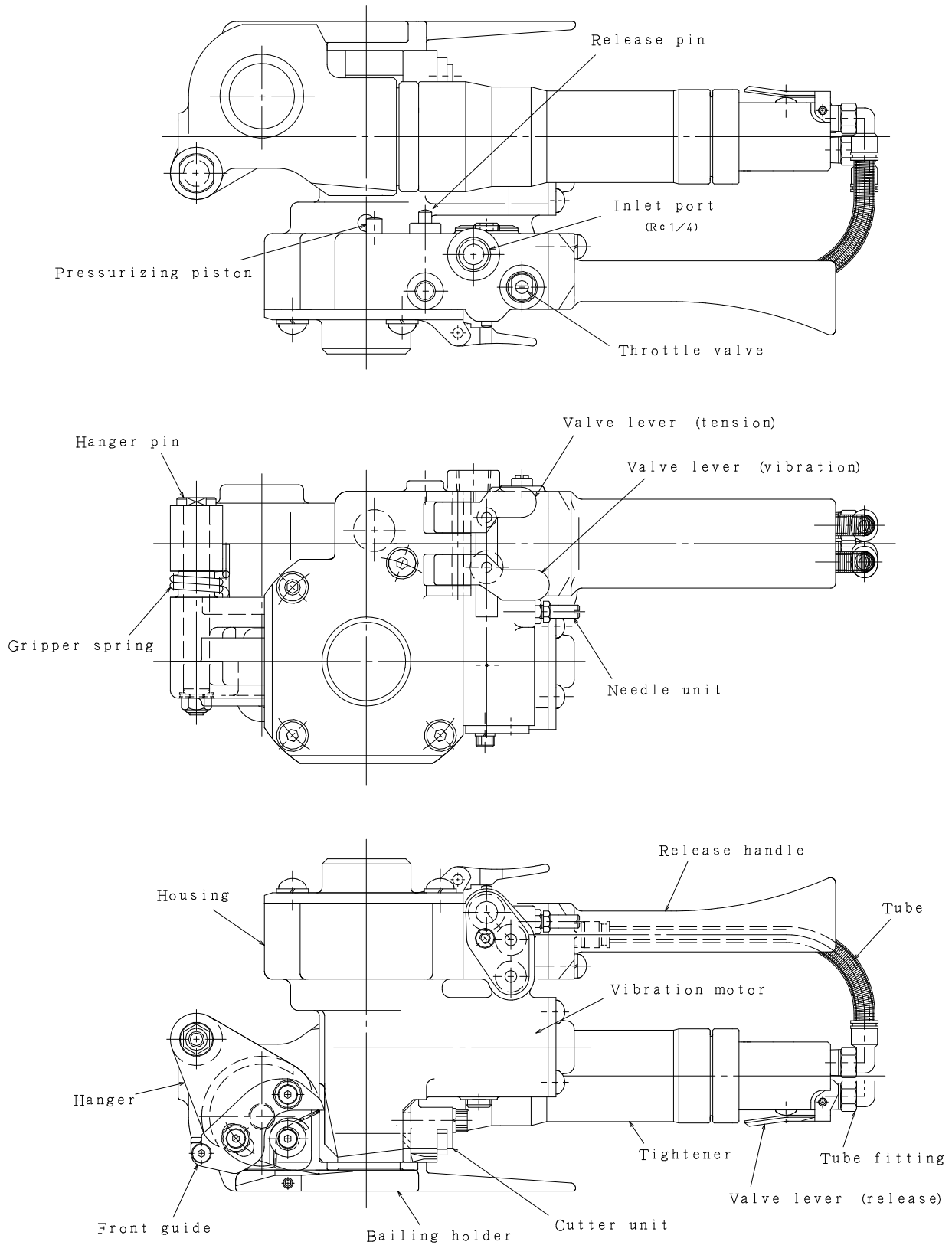

5-2. Inside names

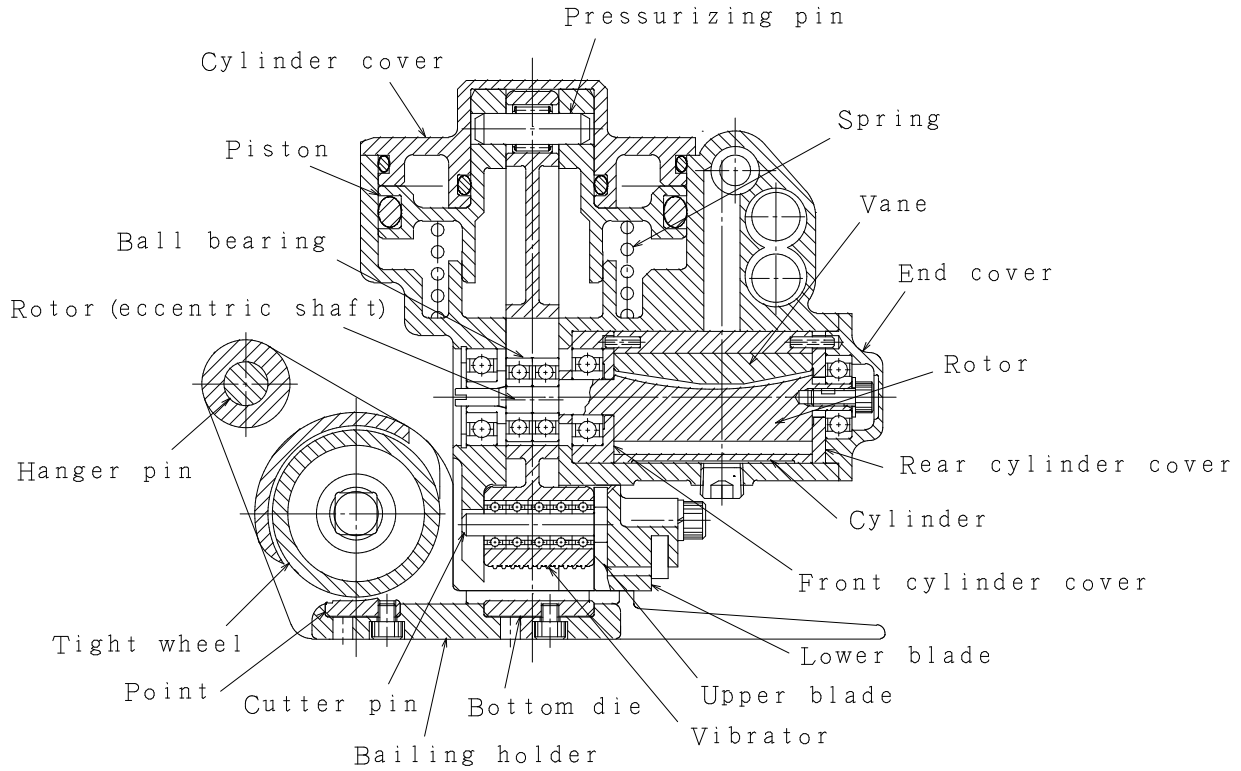

5-3. Valve inner part names

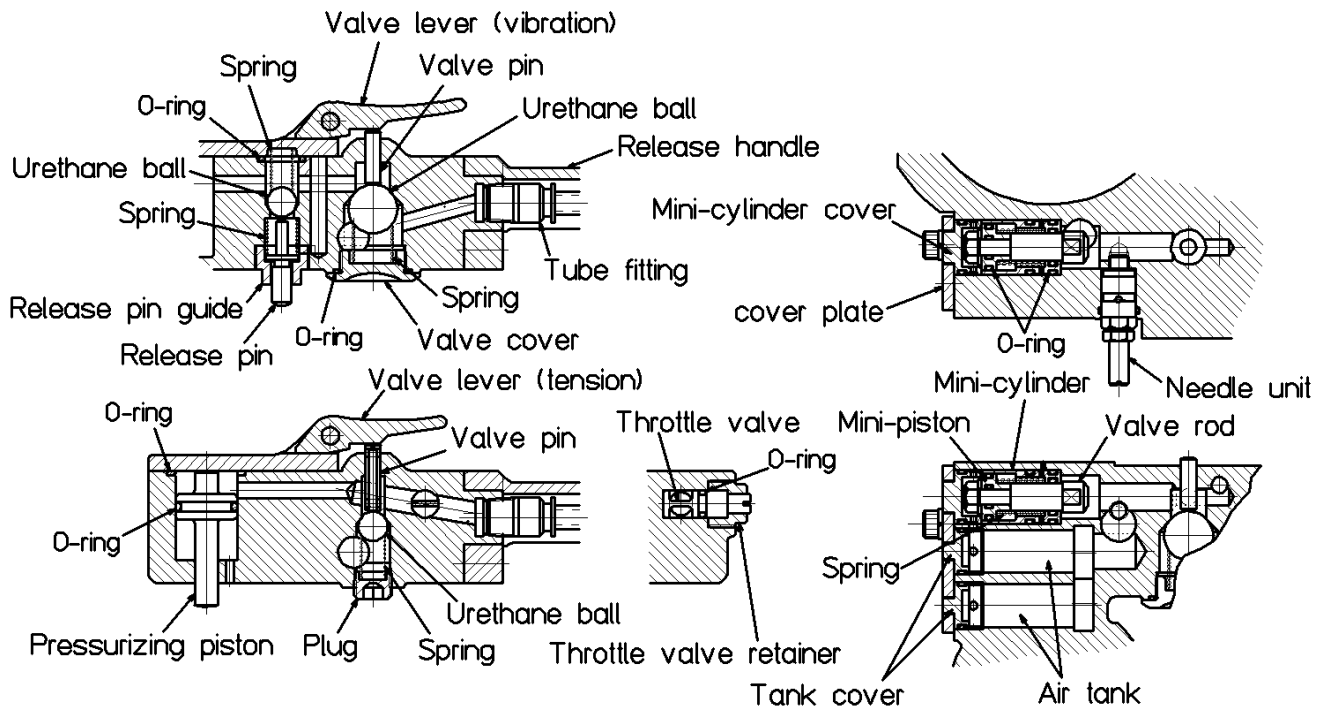

6. Operating Method

6-1. How to bind with a strap

Bind a strap around the package as shown in the figure.

Hold the overlapped two straps with the left hand so as to allow the end of the strap to lead out forward by approximately 30 cm. Next, tighten the upper strap with the right hand to eliminate unnecessary strap slack.

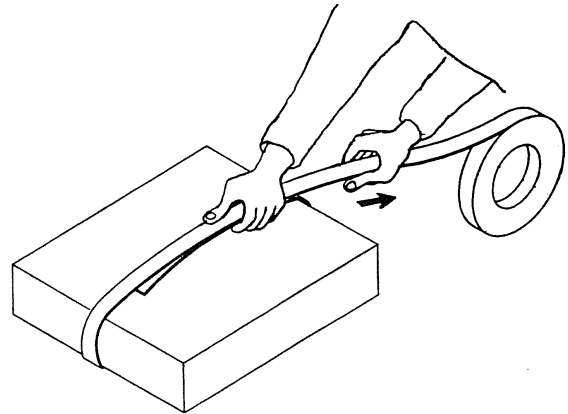

6-2. How to set a strap

Hold the handle and the tightener together with the right hand and lift the tight wheel to make a clearance to insert the strap.

Next, insert the overlapped two straps from the side with the left hand.

[Caution] Separate the upper strap and the lower strap by the lower blade of the cutter, and insert the upper strap and the lower strap separately on and under the lower blade.

When the right hand is released from the handle, the tight wheel presses the strap.

[Caution] At this point, check that the two straps are securely inserted inside the side guide.

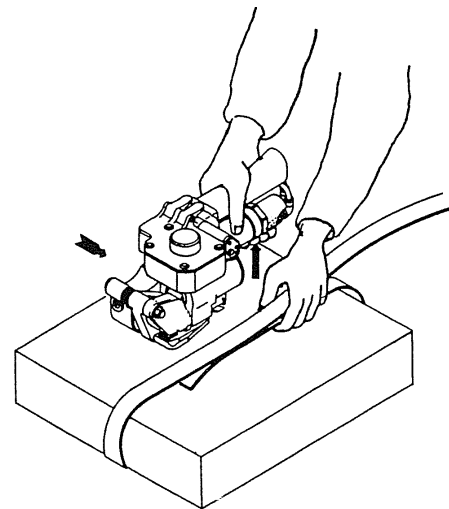

6-3. Tightening

Hold the release handle, and press the valve lever on the upper right side of the cylinder with the thumb of the right hand, and the tight wheel starts rotating and tightening the strap.

The tightener stops tightening automatically when the stalling torque is reached.

[Adjustment of tightening force]

The tightening force can be changed by adjusting the air supply flow rate to the tightener with the throttle valve.

Additionally, the tightening force can be changed also by changing the pneumatic pressure by adjusting the regulator of the air source.

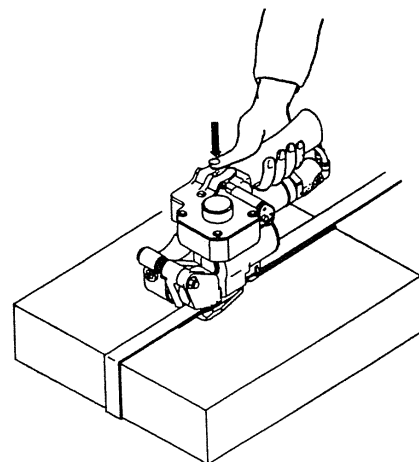

6-4. Pressurizing, cutting, welding

Hold the release handle and press the left side lever with the thumb of the right hand, the cutter lowers and cuts off the unnecessary following strap, and at the same time the vibrator vibrates at a high speed while pressurizing the strap and starts welding.

[Caution]

The vibrator stops automatically with the vibration timer.

Keep pressing the lever until the motor stops.

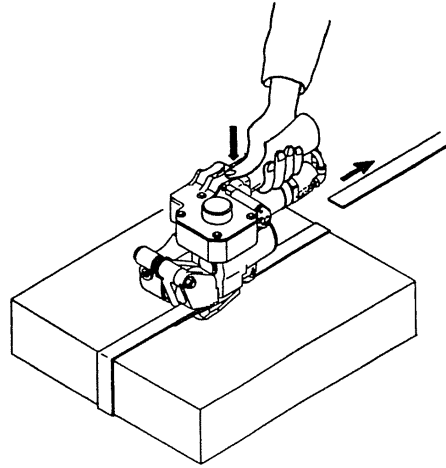

Adjusting example of the vibration timer

To obtain the optimum welding strength, adjust the needle unit referring to the table below to set the time to keep pressing the valve lever (when air source pressure is 0.5 MPa).

Kind of strap	Polyester strap				
Width x thickness mm	16×0.6	19×0.7	19×1.2	25×0.8	25×1.0
Base material strength N (Reference Value)	3,920	5,880	9,800	8,330	10,780
Vibration time sec	0.5	1.0	2.0	2.5	3.0
Welding strength N (Reference Value)	2,940	4,410	7,350	6,370	7,840

- Turning the needle unit clockwise lengthens the vibration time.
- Turning the needle unit counterclockwise shortens the vibration time.

6-5. Removing the tool

The vibration automatically stops with the vibration timer.

Leave it as it is for 2 to 3 seconds and pressurize and cool down the melted part.

Next, operate the valve lever (release) of the tightener rear part with the right little finger to rotate the tight wheel to reverse and release the tightening force, and then hold the release handle and the tightener together, lift the tightener, move the tool main body sideways to pull out the bailing holder from the bottom of the bound strap.

[Caution]

If the tightener is forcibly pulled up, the machine may be broken.

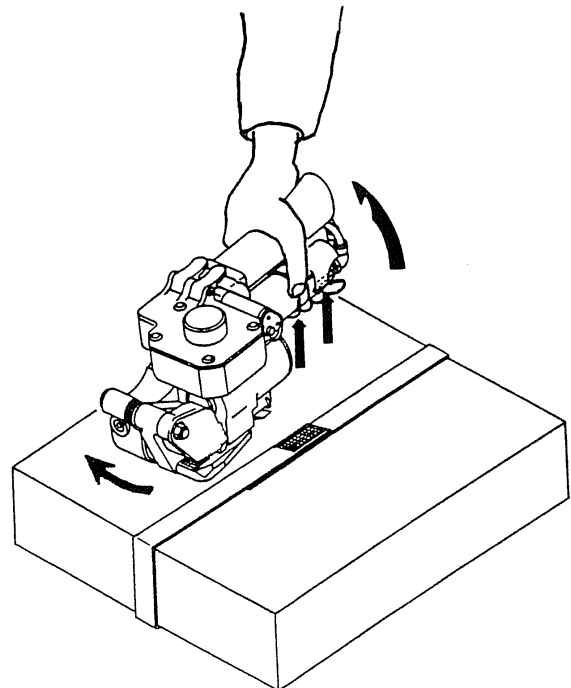

7. Cautions for Use

7-1. Daily care and cleaning

After using the tool, clean the tight wheel part and the vibrator part with a wire brush or by air blowing, to remove dust and melting residue.

In addition, retighten the mounting bolts with the included hexagon wrench to make sure that they are not loose.

7-2. Tool balancer

The empty weight of this tool is 3.8 kg. This can be used by one hand.

When using by hanging with a tool balancer, please use the suspension attached.

7-3. Cautions when tightening

(1) Lining-up of the strap

If the overlapped upper strap and the lower strap are not neatly aligned, the strap deviates in the width direction when tightening resulting in bad appearance as well as worsening the welding strength.

To avoid this, insert the two straps to the end when setting the strap to the tool, and check that the upper strap and the lower strap are neatly aligned before starting tightening. It is also important to eliminate the slack of the upper strap before inserting the strap.

(2) Adjustment of the tightening force

If the strap is tightened too strongly, trouble may occur such as the strap may be broken, or the strap surface will be scraped off.

In such a case, adjust the throttle valve to reduce the air flow rate to set to the appropriate tightening force before use.

(3) Locking of the tight wheel (strap entanglement)

When the strap is tightened with the tight wheel and strap tension is generated, the strap may stick fast to the tight wheel.

At this point, if the tightener is forcibly lifted, the part may be broken. In such a case, press the valve lever (release) on the rear bottom side of the tightener to reversely rotate the tight wheel and to loosen the strap tension, whereby the tightener can easily be pulled up.

7-4. Welding strength

To obtain strong welding strength, it is important to melt, pressurize and cool down the strap surface sufficiently.

The required vibration time differs depending on

- Material of the strap (ester strap < PP strap)
- Width of the strap (wide strap > narrow strap)
- Thickness of the strap (thick strap > thin strap)
- Air pressure (high < low).

In the case of the ester strap, in general, the welding strength tends to be weaker, as the vibration time is longer. A too long vibration time only increases the melted amount unnecessarily. The melted resin will extrude outside the strap, and the melted residue will remain on the welding part of the tool, which may cause trouble in the next action.

As for a simple reference to judge the optimum vibration time, the state that the melted resin from the edge of the strap comes out of the strap by approximately 0.5 to 1.0mm is most preferable.

Set the vibration time to create such state.

8. Attached Parts

These are shims used according to the thickness of a strap and Tube fittings for Tightener.

1) Main body

Key NO.	Part name	Size	Quantity	Use purpose
36	Shim (for point)	16×18×0.2 ^t	2 sheets	For thin strap
39	Shim (for bottom die)	18×24×0.2 ^t	2 sheets	For thin strap

2) Tightener

Key NO.	Part name	Size	Quantity	Use purpose
58	Tube fitting PL6-01M	-	2	-

9. Check Points After Assembly

9-1. Clearance check of the tight wheel.

Measure the clearance between the serrations of the #9 point and the #10 tight wheel with a clearance gauge. A clearance equivalent to the thickness for one strap for use is necessary.

Example)

When a strap thinner than 0.8 mm is used, it is necessary to reduce the clearance by inserting 1 or 2 sheets of #36 shim that is an accessory part to the bottom of the #9 point according to the thickness of the strap.

The thickness for one shim is 0.2 mm.

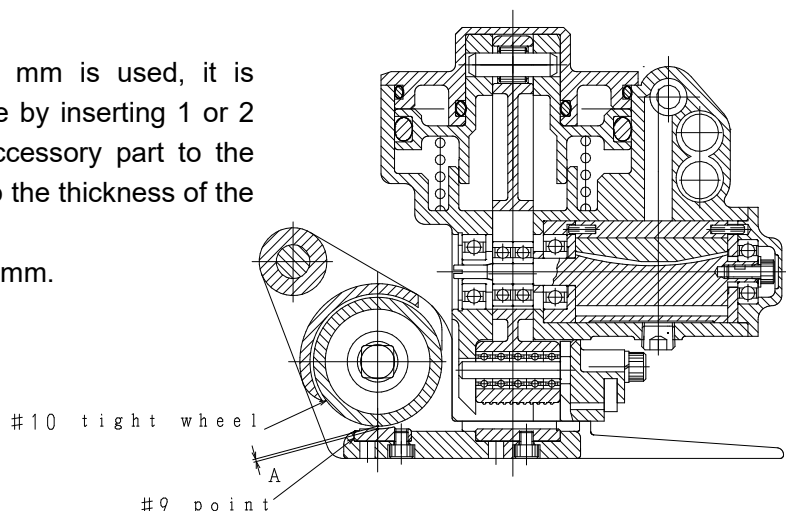

9-2. Clearance check of the vibrator

After mounting the #3 bailing holder, check the clearance (dimension B of the figure below) of the serrations of the #7 bottom die top surface and the serrations of the #8 vibrator bottom in the following procedures.

- (1) Connect the assembled tool to the air source and press down the vibration lever to lower the cylinder piston undermost.
- (2) In the state that the pressurizing cylinder is lowered, measure the clearance (dimension B in the figure below) of the vibrator with a clearance gauge.

The appropriate amount of the clearance is 0.4 to 0.6 mm.

In the case of use of a specially thin strap, insert the accessory #39 shim (thickness 0.2 mm) to the bottom of the #7 bottom die to reduce the clearance to 0.2 to 0.4 mm.

[Caution]

If idle operation (operation without strap) is carried out in the state that too many shims are inserted and the clearance B is eliminated, the serrations of the vibrator and the button die will collide and the parts will be instantly damaged, so absolutely never insert too many shims.

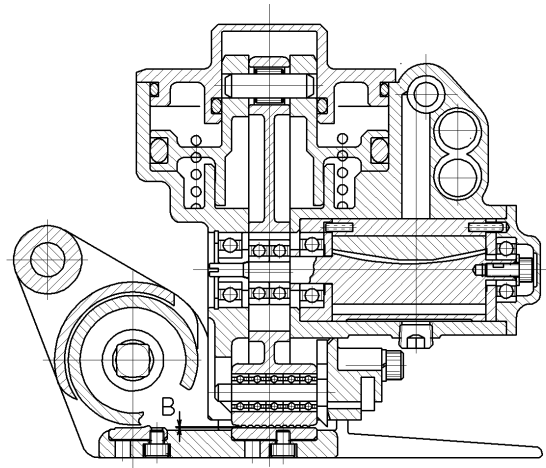

10. Trouble Shooting

The causes and remedies for troubles that may occur in this tool are specified.

Contents of trouble	Causes	Remedies
The air motor of the tightener does not rotate.	1. Dust is caught in the air motor of the tightener.	1. When dust is caught in the air motor, the tightener needs to be disassembled.
	2. The air motor of the tightener does not rotate due to oil runout.	2. The rotor is seized due to oil runout. Fill several drops of lubrication oil from the inlet of the coupler.
	3. The throttle valve is excessively throttled and the air flow rate to the air motor is too low.	3. Adjust the throttle valve to increase the air flow rate to the air motor.
The tight wheel scrapes off the surface of the strap.	1. The clearance of the tight wheel is too large.	1. Adjust the clearance between the tight wheel and the point using the accessory shim. (1) In the case of a 0.5 mm strap Clearance 0.5 mm (2) In the case of a 1.0 mm strap Clearance 1.0 mm
	2. The tightening force is too strong with respect to the thickness of the strap.	2. Adjust the throttle valve and decrease the air flow rate to the air motor.
When starting to tighten the strap, the tool moves forward.	1. Scraped chips of the strap remains on the surface of the point and the lower strap is slipped.	1. Clean the point with a wire brush or by air blowing.
	2. The serration of the point is worn out or the tips are chipped.	2. If wearing or damage is considerable, replace it with a new one.
	3. The tightening force is too strong with respect to the thickness of the strap and the strap surface is scraped off.	3. Adjust the throttle valve and reduce the air flow rate to the air motor.

Contents of trouble	Causes	Remedies
Strap cannot be cut.	1. The upper blade or the lower blade is worn out or defective.	1. Replace the upper blade or the lower blade with a new one.
	2. The upper strap or the lower strap deviates in the width direction and comes out from the cutter width.	2. When attaching a strap, check that the two straps are both neatly inserted into the guide.
Strap cannot be welded.	1. The vibration time is too short.	1. Set the time of the vibration timer longer.
	2. The pressure of the air source is too low.	2. Check that the source pressure is 0.5 MPa or more.
	3. The size of the air hose is too small and the air pressure lowers to 0.4 MPa or less.	3. Replace it with a larger hose. (Use a hose with an inner diameter of $\varnothing 9.5$ mm or more.)
	4. Strap scraped chips are clogged in the serrations of the vibration part.	4. Clean the serration (vibrator part and the bottom die part) with a wire brush or by air blowing.
	5. The rotation speed of the vibrator is lowered due to oil runout, and frictional heat is not sufficiently generated.	5. Fill several drops of lubrication oil from the inlet of the coupler.
The tool cannot be removed from the strap after welding.	1. Since the tight wheel does not rotate in reverse, the remaining tension of the strap cannot be released.	1. Rotate the tight wheel in the reverse direction with the vibrator on the tightener rear part bottom surface, and reduce the remaining tension.
	2. The vibrator still presses the strap without rising.	2. Hold the tightener and the handle at the same time, and make the tightener contact with the release pin to open the check valve.
The strap frays when welding.	1. The thickness of the strap is insufficient.	1. Use thicker strap. For example, Our Company "ESTERTOP"
	2. The vibration time is too long.	2. Set the time of the vibration timer shorter.

11. Pneumatic Diagram

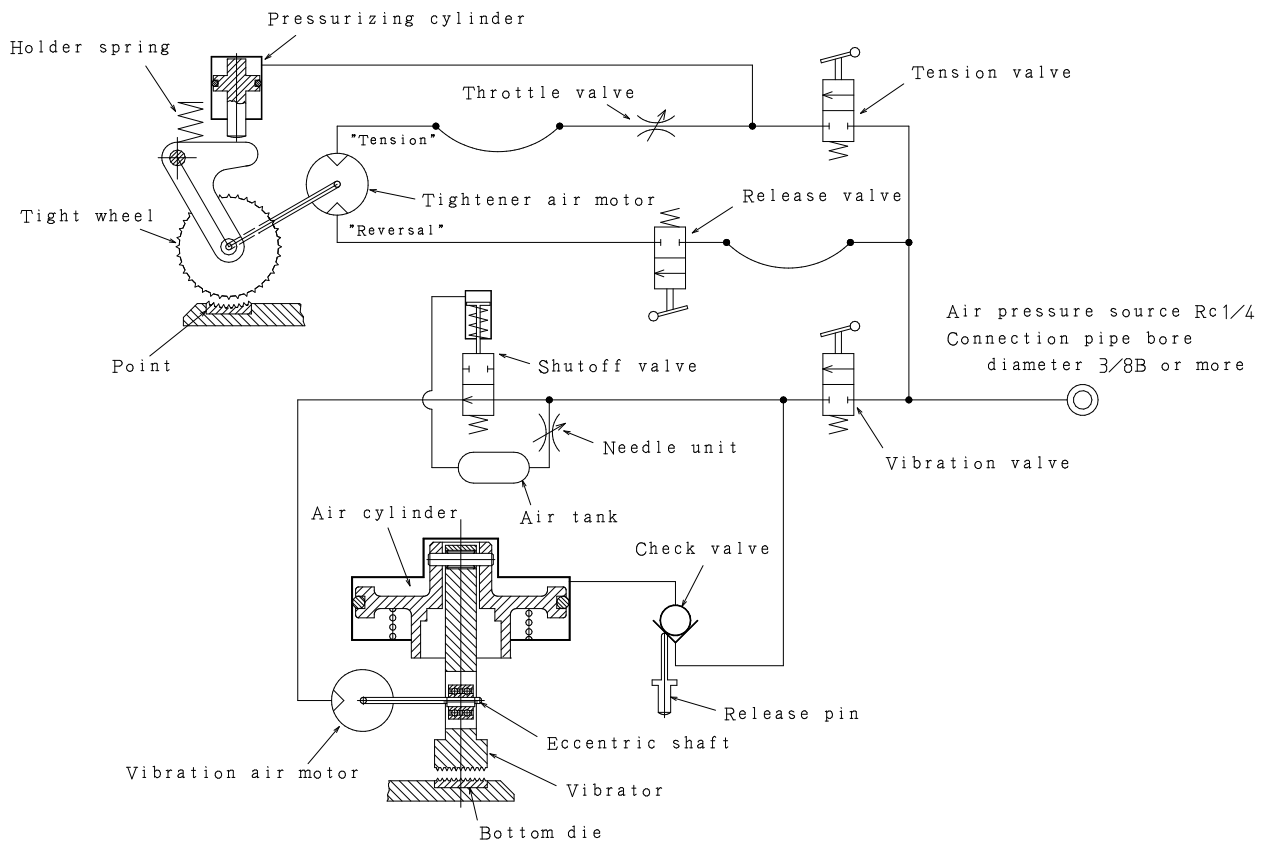

14-1. Explanation of action

- (1) When the lever for the tensioning valve is pressed, the tightener air motor rotates in the strap tightening direction, and at the same time, the pressurizing cylinder pressurizes down the tight wheel.
- (2) When the lever for the vibration valve is pressed, the air cylinder is pressurized down, the straps are brought into close contact, and at the same time, the vibration motor rotates to start vibration (welding).
- (3) When the inside of the tank is pressurized, the shutoff valve closes, and vibration (welding) is stopped.
- (4) When the lever for the release valve is pressed, the tightener air motor rotates in reverse, and the strap engagement is released.
- (5) By holding the release handle and the tightener at the same time, the release pin acts and the pressure inside the cylinder is released to release the strap.



KOHAN KOGYO CO., LTD.

■帯鋼機器営業部門

東京営業部 〒141-0022 東京都品川区東五反田 18 番 1 号 (大崎フォレストビルディング 19F)
Tel. 03-4531-6891、FAX. 03-3280-8162

大阪営業部 〒541-0041 大阪市中央区北浜 4 丁目 7 番 19 号 (住友ビル 3 号館 4F)
Tel. 06-6223-4680、FAX. 06-6223-4681

下松営業部 〒744-0011 山口県下松市西豊井 1394 番地
Tel. 0833-43-1824、FAX. 0833-44-0964

Tokyo Sales Department Osaki Forest Building, 2-18-1 Higashi-Gotanda Shinagawa-Ku,
Tokyo, 141-0022, Japan, Tel. +81-3-4531-6891

Osaka Sales Department Sumitomo Building 3Go-Kan, 4-7-19 Kitahama, Chuo-Ku,
Osaka, 541-0041, Japan, Tel. +81-6-6223-4680

Kudamatsu Sales Department 1394 Nishitoyoi, Kudamatsu, Yamaguchi,
744-0002, Japan, Tel. +81-833-43-1824

■機 器 工 場 〒744-0011 山口県下松市西豊井 1394 番地 Tel.0833-43-2640

Machinery Works 1394 Nishitoyoi, Kudamatsu, Yamaguchi 744-0011, Japan
Tel. +81-833-43-2640

■海外営業所 / 現地法人

中 国 / China Branch

SHANGHAI TOYO KOHAN TRADING CO., LTD. "Kohan Kogyo" Division
Room 2701, Shenggao International Building, No137, XianXia Road Shanghai 200051, China
Tel. +86-21-6259-1708, Fax. +86-21-6270-3308

台 湾 / Taiwan Branch

KOHAN KOGYO CO., LTD. TAIWAN BRANCH (JAPAN)
No. 26, Ln. 76, Shepi Rd., Fengyuan Dist., Taichung City 420077, Taiwan (R.O.C.)
Tel. +886-4-2259-2850, Fax. +886-4-2259-2851

韓 国 / Korea Branch

KOHAN KOGYO KOREA CO., LTD.
No.115-215, 132-Dong, Busan T-PLEX ,41,Yutongdanji-1Ro(Daejeo-2Dong), Gangseo -Gu, Busan,
46721, Korea
Tel.+82-51-710-6342 Fax. +82-70-8282-0526

(2025.01)